

**35th International Technical Conference on Clean
Coal and Fuel Systems, June 6-10, 2010**

***Use of Waste Heat and CO₂
Compression Heat to Reduce
Penalty due to Post-Combustion
CO₂ Capture***

Nenad Sarunac and Carlos E. Romero

*Energy Research Center
Lehigh University, Bethlehem, PA*

Barry Liebowitz

New York State Research and Development Authority, Albany, NY

Presentation Outline

- *Project goals and objectives*
- *Modeling and optimization of MEA CO₂ capture process using ASPEN Plus.*
- *Boiler-Turbine Cycle Integration*
 - *Feedwater Heating (FWH)*
 - *Advanced Air Preheating*
 - *Steam turbine cycle modeled by PEPSE*
- *Integration of CO₂ scrubber with waste heat sources.*
- *Integration of CO₂ compression train and turbine cycle.*
- *Partial CO₂ scrubbing*
- *Conclusions*

Project Goals and Objectives

- *Determine efficiency improvements that can be achieved at **existing power plants** by using heat recovered from flue gas and CO₂ compression heat to partially offset efficiency and capacity losses due to post-combustion CO₂ capture retrofit.*
 - *Optimize MEA CO₂ capture process to reduce reboiler thermal duty and cooling loads.*
 - *Use heat recovered from flue gas and CO₂ compression heat to improve performance of steam cycle.*
 - *Integrate CO₂ stripper with plant waste heat sources to reduce steam extraction from LP turbine for solvent regeneration and process energy requirements for CO₂ capture.*
 - *Investigate thermal integration options*
 - *Investigate partial CO₂ scrubbing and determine its effect on unit efficiency and capacity.*
- *Analyses performed for 600 MW subcritical PC-fired unit*

***Modeling and Optimization of
MEA CO₂ Capture Process
Using Aspen Plus***

Conventional Amine (MEA) CO₂ Capture Process

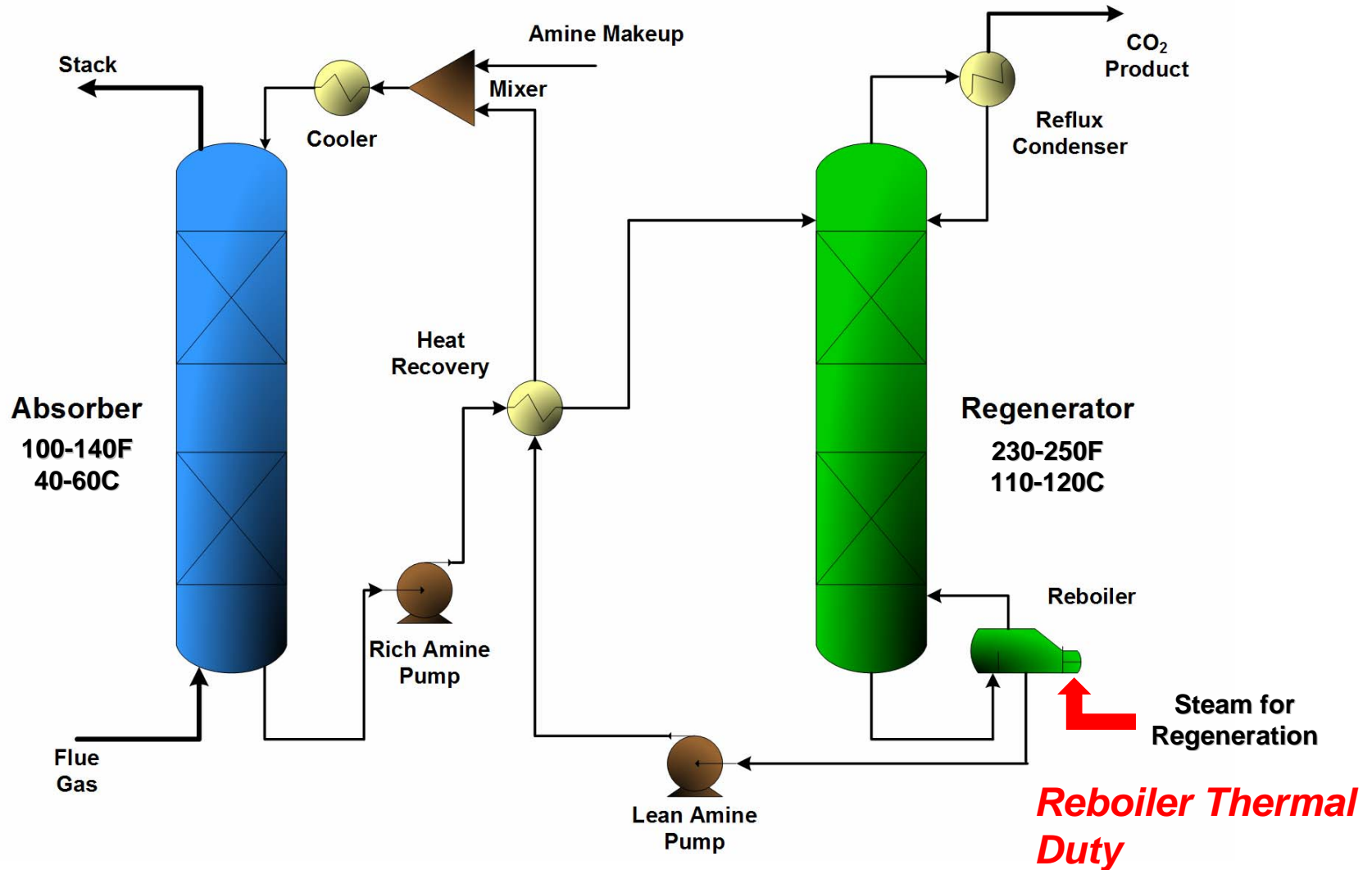

ASPEN Plus Model Diagram of MEA- CO₂ Capture Process

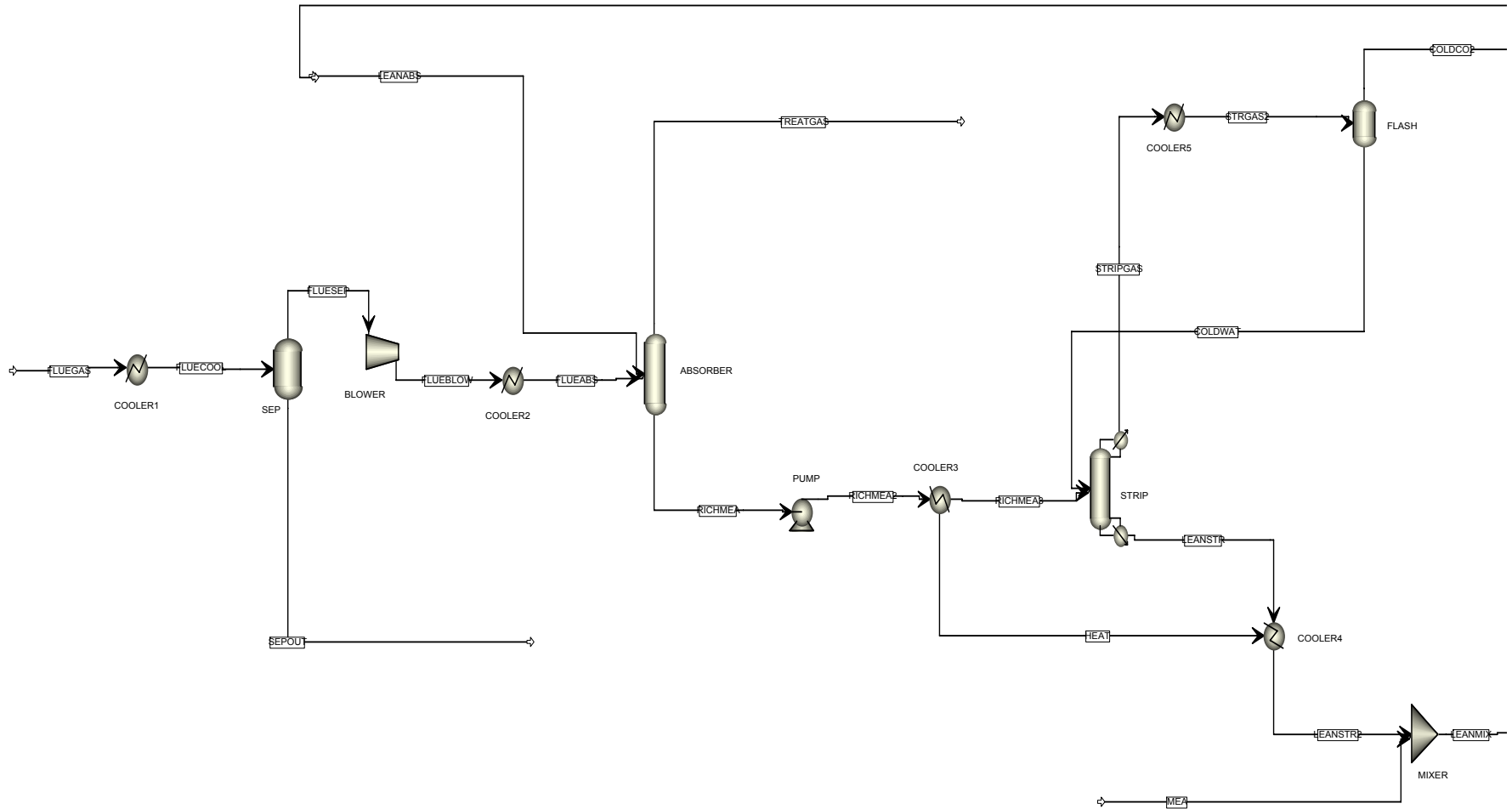

Parametric Study: Minimization of Reboiler Thermal Duty

- *Sensitivity analysis was performed where parameters affecting performance of CO₂ capture process were varied to improve performance of MEA CO₂ capture process and **minimize reboiler thermal duty.***
- *The following process parameters were varied:*
 - *CO₂ stripper operating pressure.*
 - *Solvent circulation rate/CO₂ lean solvent loading (mol CO₂/mol MEA).*
 - *MEA weight percentage in absorption solvent.*
 - *CO₂ removal percentage.*
 - *Flue gas/lean solvent temperature.*

Effect of CO₂ Stripper Pressure on Reboiler Thermal Duty

ASPEN Simulation

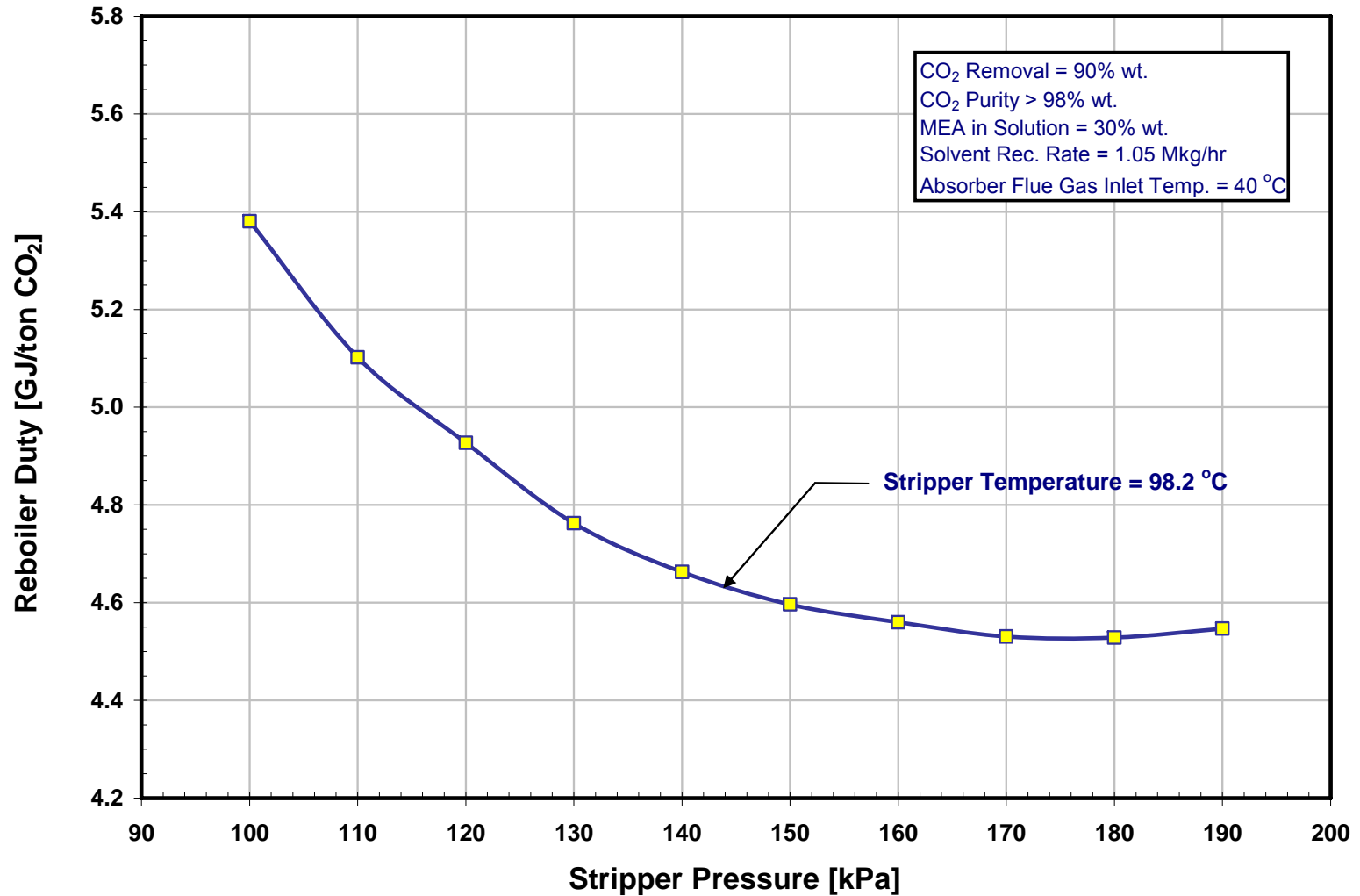

Effect of Solvent Mass Flow Rate on Reboiler Thermal Duty

ASPEN Simulation

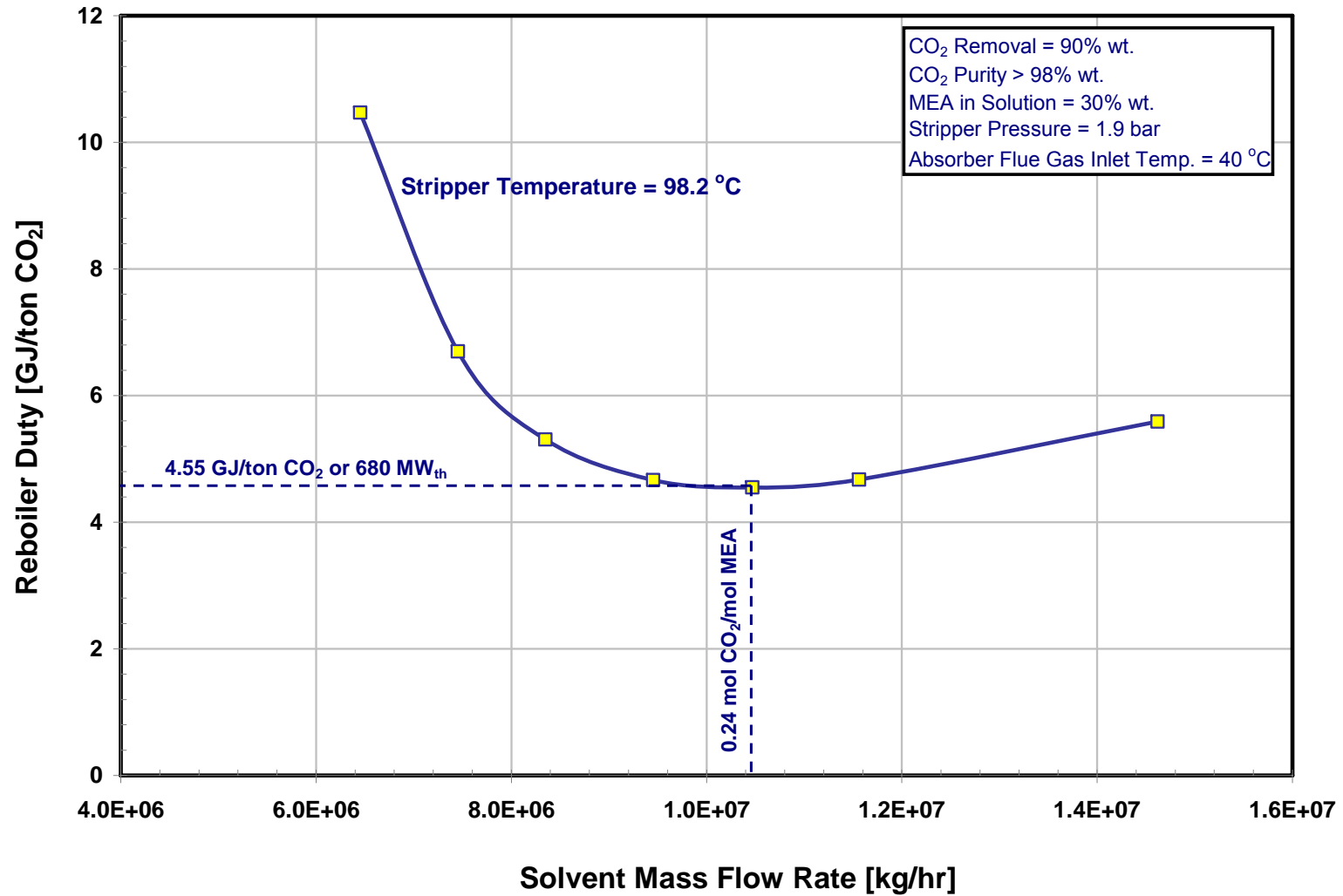

Effect of MEA Concentration in Solvent on Reboiler Thermal Duty

ASPEN Simulation

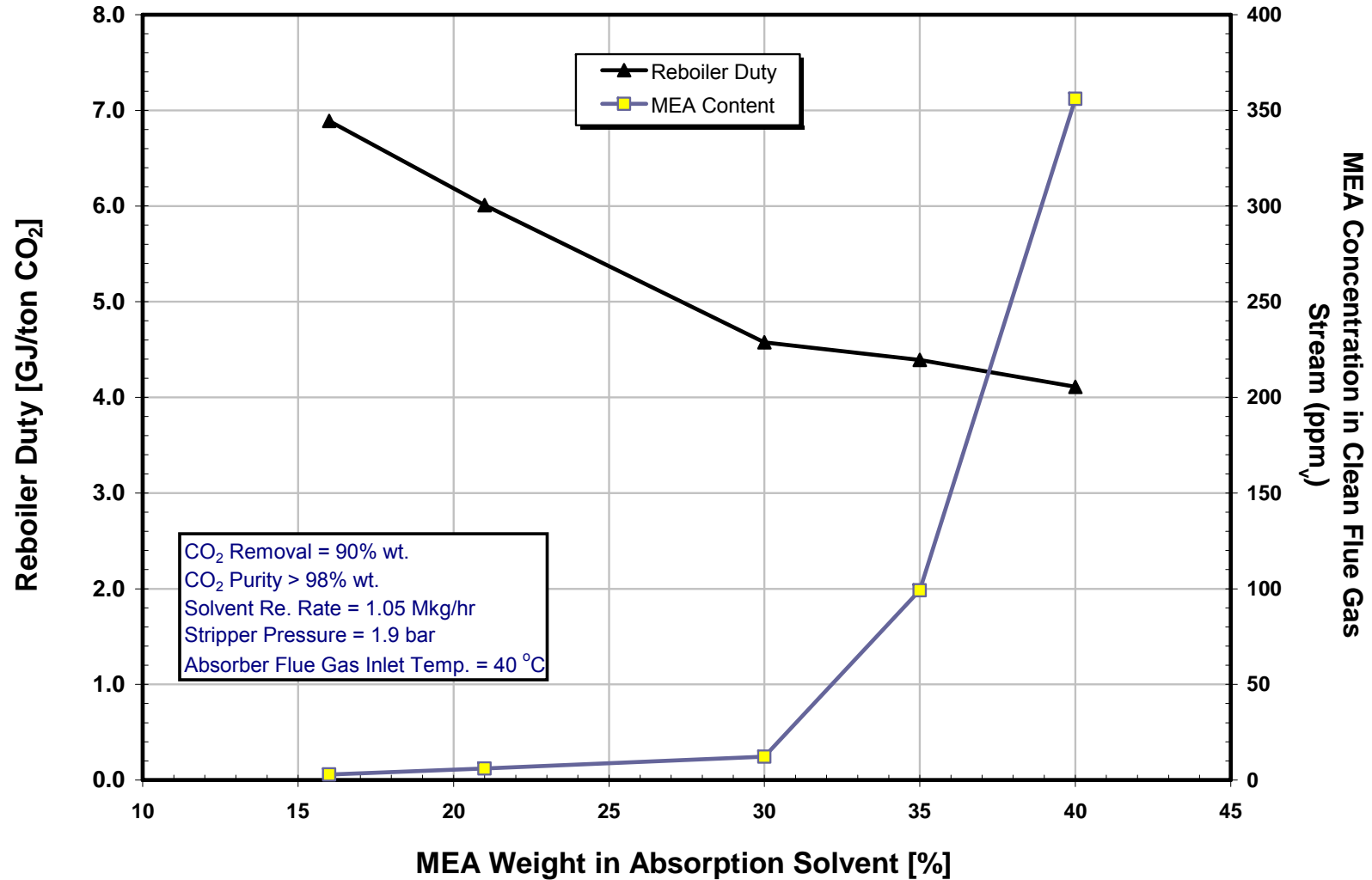

Effect of CO₂ Removal on Reboiler Thermal Duty

ASPEN Simulation

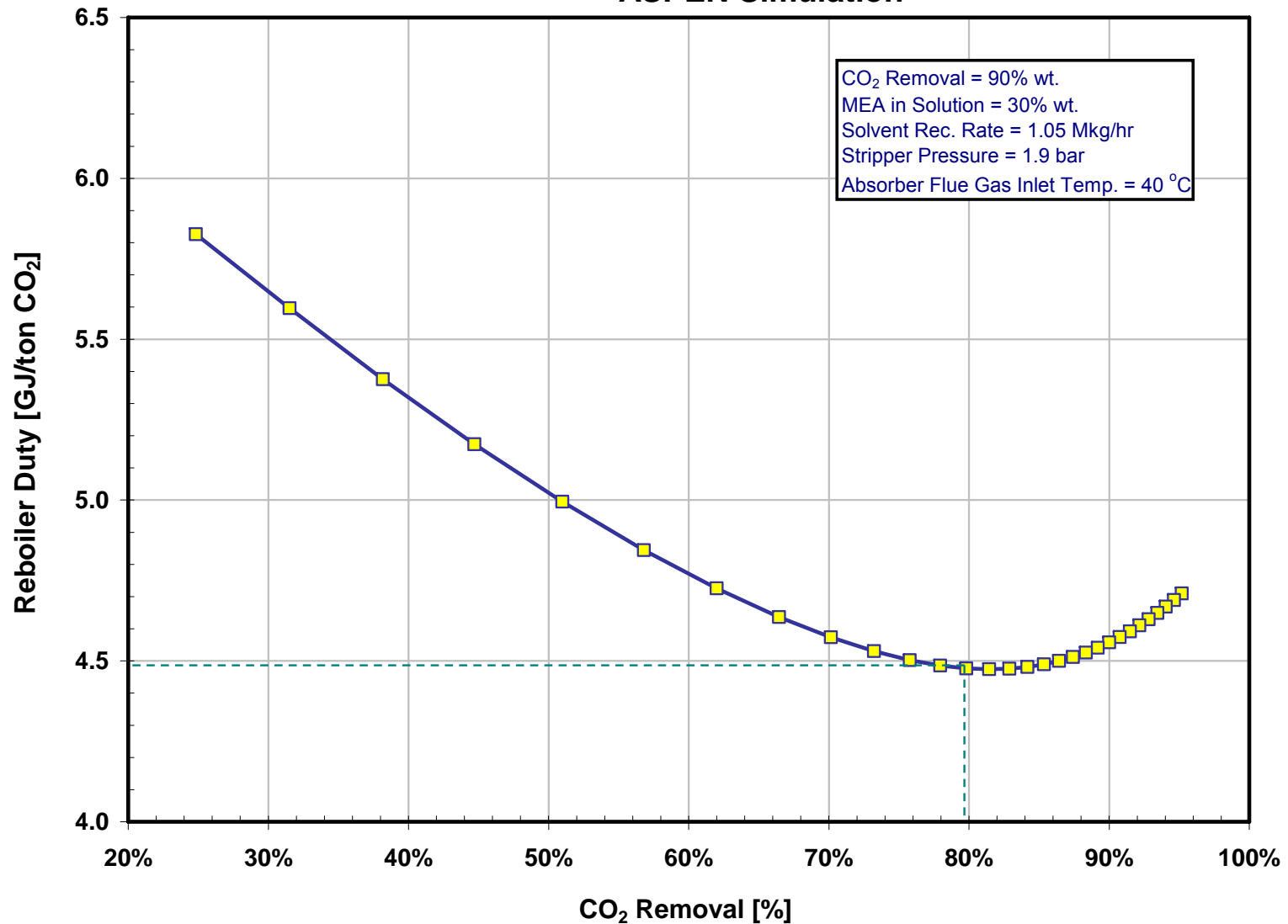

Effect of Absorber Inlet Flue Gas Temp. on Reboiler Thermal Duty

ASPEN Simulation

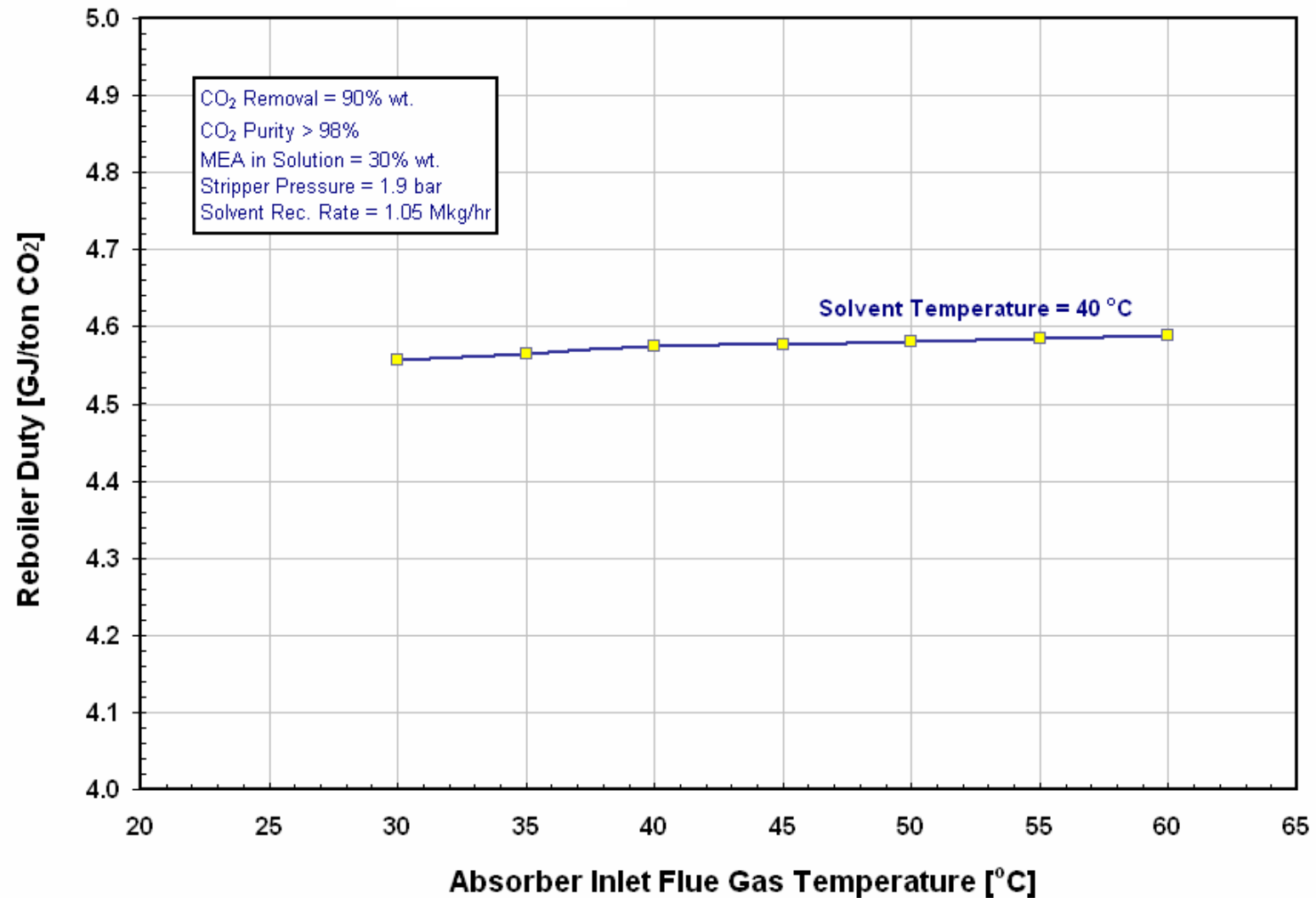

Effect of CO₂ Concentration in Flue Gas on Reboiler Thermal Duty

ASPEN Simulation

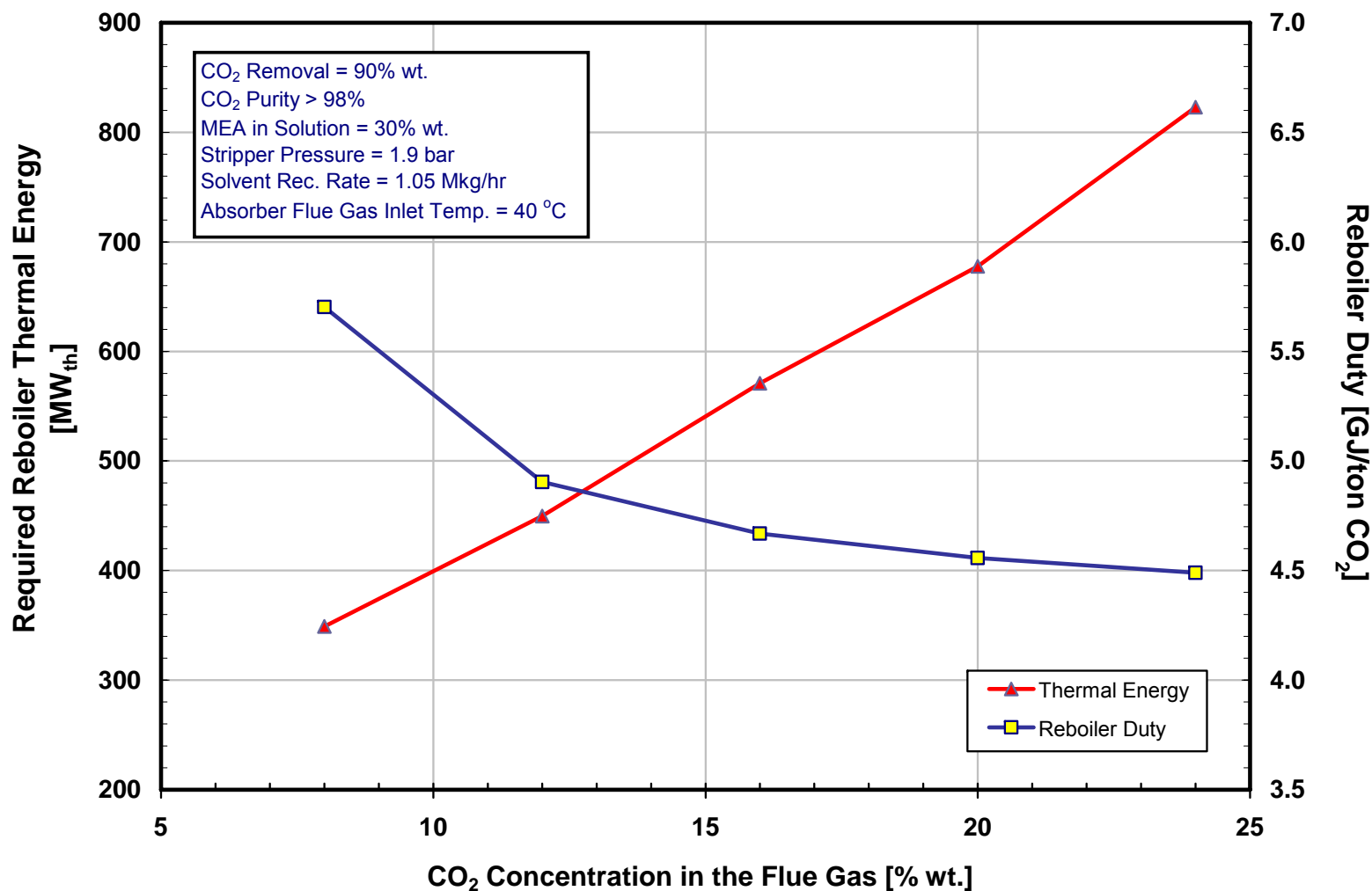

Feedwater Heating & Advanced Air Preheating with Two-Stage CXE for CCS

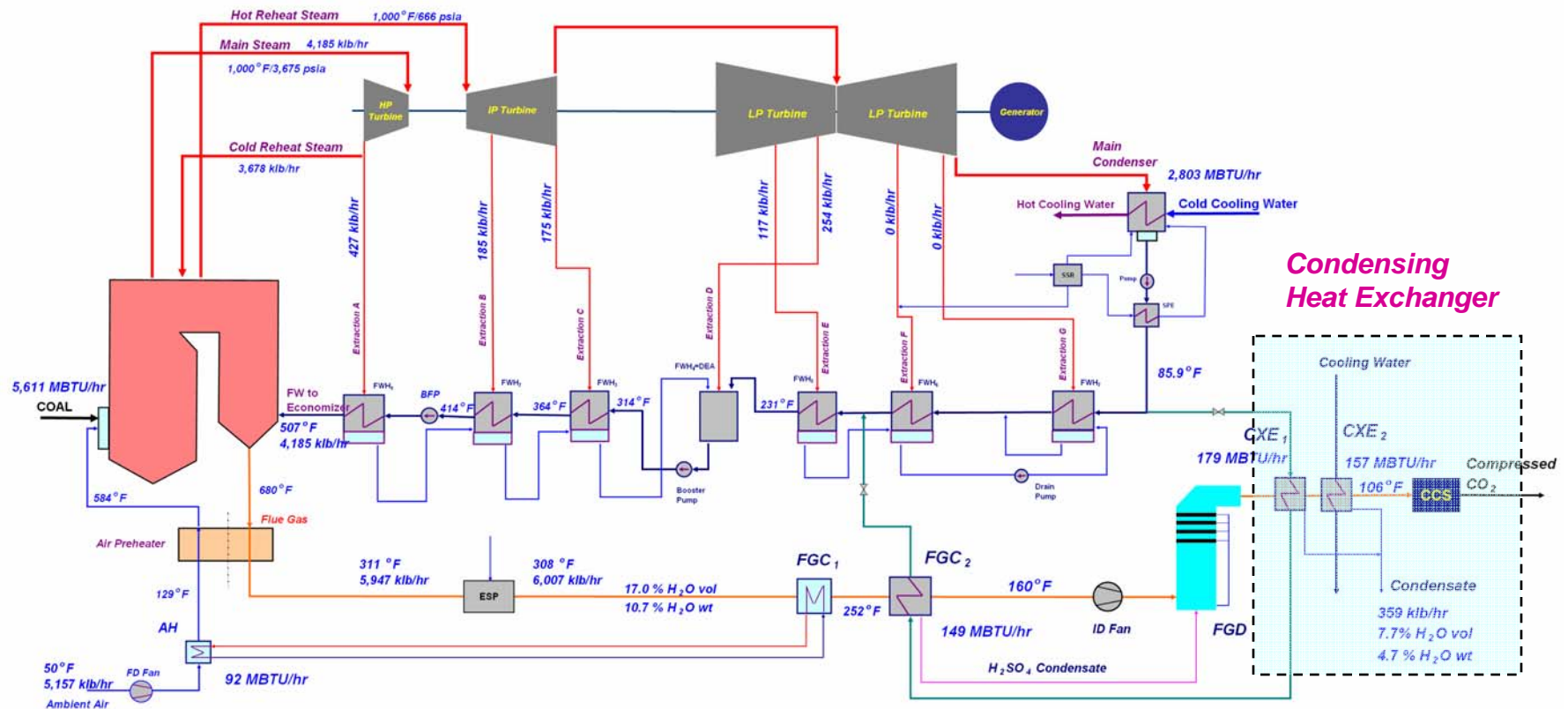

CXE: Condensation Efficiency

Condensation Efficiency = Percentage of flue gas moisture condensed out the flue gas stream

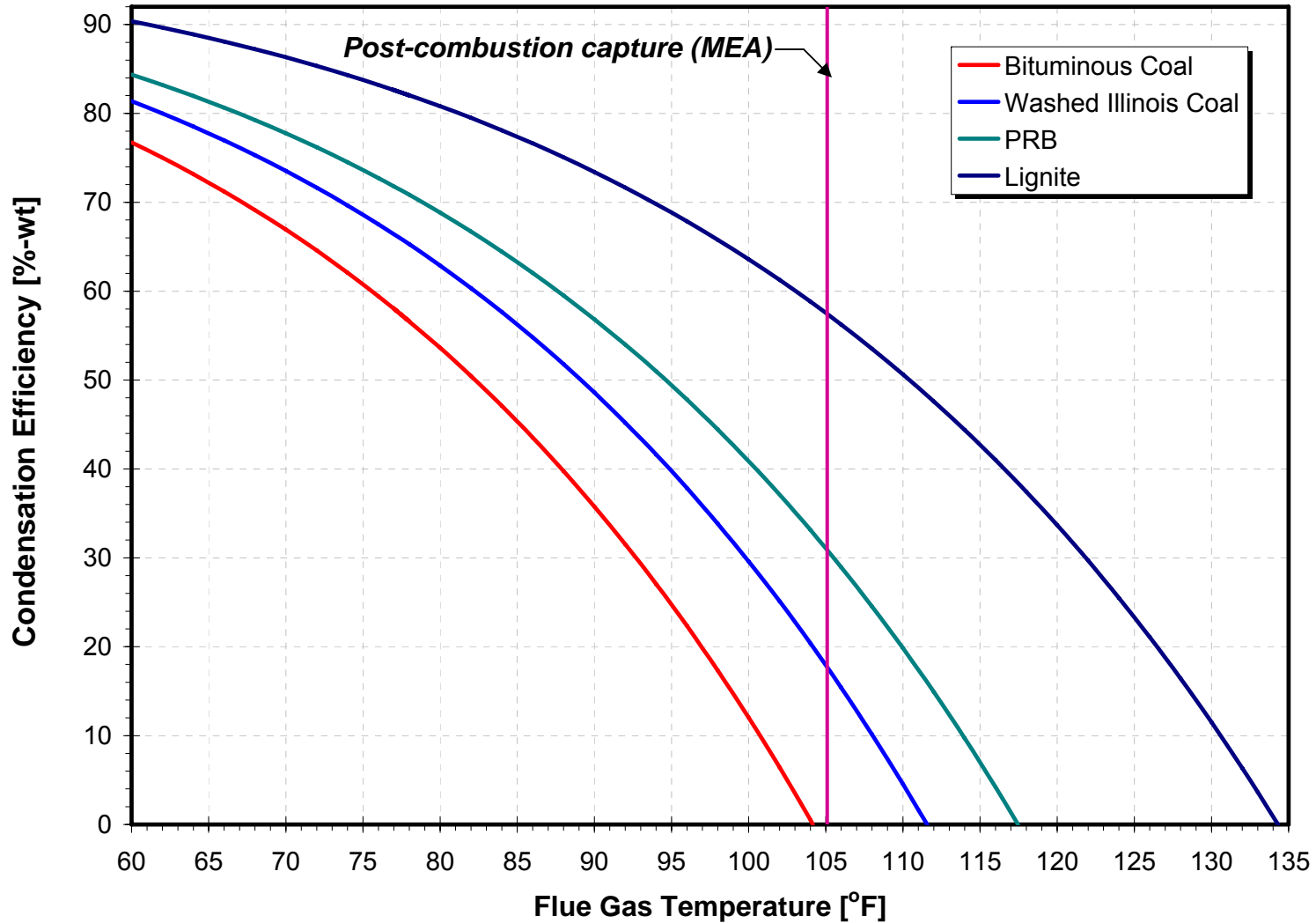

Optimization Results

MEA System Optimal Operating Point	
Flue Gas Mass Flow Rate (t/h)	3049.9
Solvent Mass Flow Rate (t/h)	10827.4
MEA Conc. n Absorption Liquid (wt. %)	30.0
Amine Rich Loading (mol CO2/mol MEA)	0.480
Amine lean Loading(mol CO2/mol MEA)	0.240
Stripper Reboiler Temperature (deg. C)	121.1
Stripper Condenser Temperature (deg. C)	100.3
Stripper pressure (bar)	1.9
Bottom to Feed Molar Ratio	0.975
Reboiler Heat Required (MW)	677.6
Reboiler Duty (GJ/hr)	2439.3
Reboiler Duty (GJ/t CO2)	4.56
CO2 Removal (wt. %)	90.0%
CO2 Purity (wt.%)	98.4%
Mass Flow Rate of CO2 Captured (t/hr)	535.3
MEA Conc. on Clean Flue Gas (ppm)	122.0
CO2 Conc. on Clean Flue Gas (ppm)	1.01

MEA System Worst Operating Point	
Flue Gas Mass Flow Rate (t/h)	3049.9
Solvent Mass Flow Rate (t/h)	10792.9
MEA Conc. n Absorption Liquid (wt. %)	30.0
Amine Rich Loading (mol CO2/mol MEA)	0.480
Amine lean Loading(mol CO2/mol MEA)	0.240
Stripper Reboiler Temperature (deg. C)	103.0
Stripper Condenser Temperature (deg. C)	96.3
Stripper pressure (bar)	1.0
Bottom to Feed Molar Ratio	0.905
Reboiler Heat Required (MW)	855.5
Reboiler Duty (GJ/hr)	2794.0
Reboiler Duty (GJ/t CO2)	5.76
CO2 Removal (wt. %)	90.0%
CO2 Purity (wt.%)	98.4%
Mass Flow Rate of CO2 Captured (t/hr)	534.4
MEA Conc. on Clean Flue Gas (ppm)	330.1
CO2 Conc. on Clean Flue Gas (ppm)	1.01

- 26.3% reduction in reboiler thermal duty

***Integration of CO₂ Scrubber
with Heat Sources:
600 MW Subcritical PC-Fired Unit***

Heat Integration of CO₂ Scrubber

- Analysis performed over range of reboiler thermal duties

Reboiler Thermal Duty	
BTU/lb CO ₂	GJ/tonne CO ₂
2,350	5.47
2,000	4.65
1,800	4.19
1,700	3.95
1,550	3.60
1,400	3.26
1,200	2.79

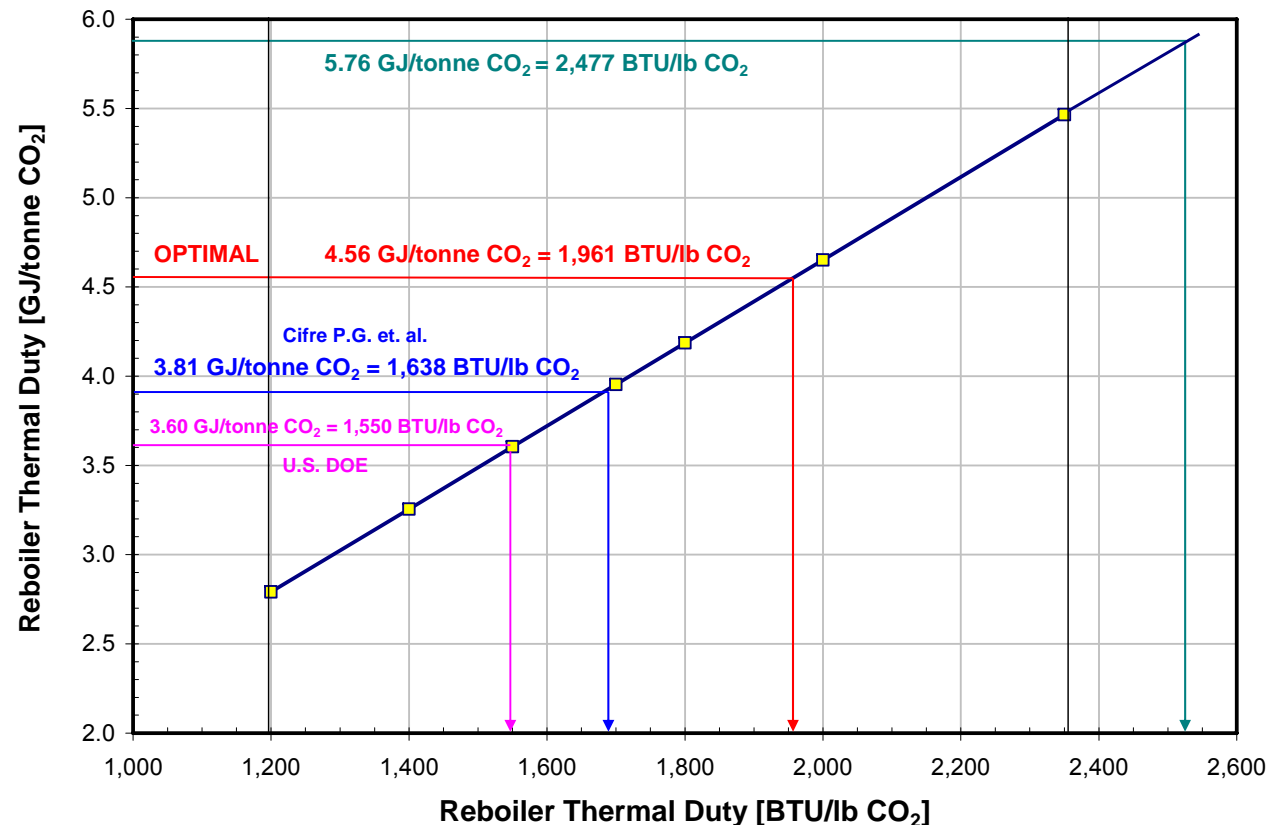

Baseline Unit Configuration

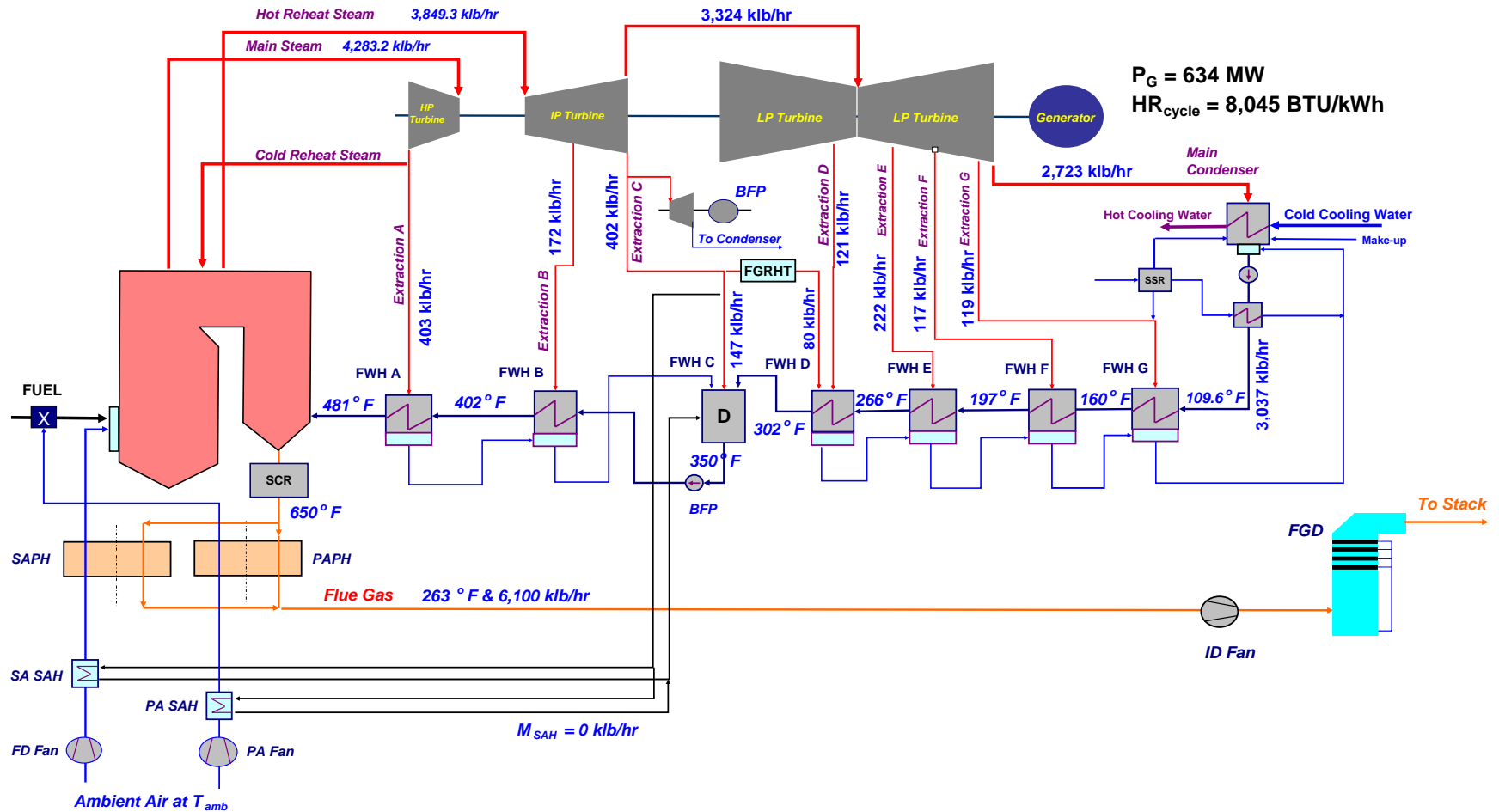

Case 1: Conventional Reboiler Integration with Steam Turbine Cycle

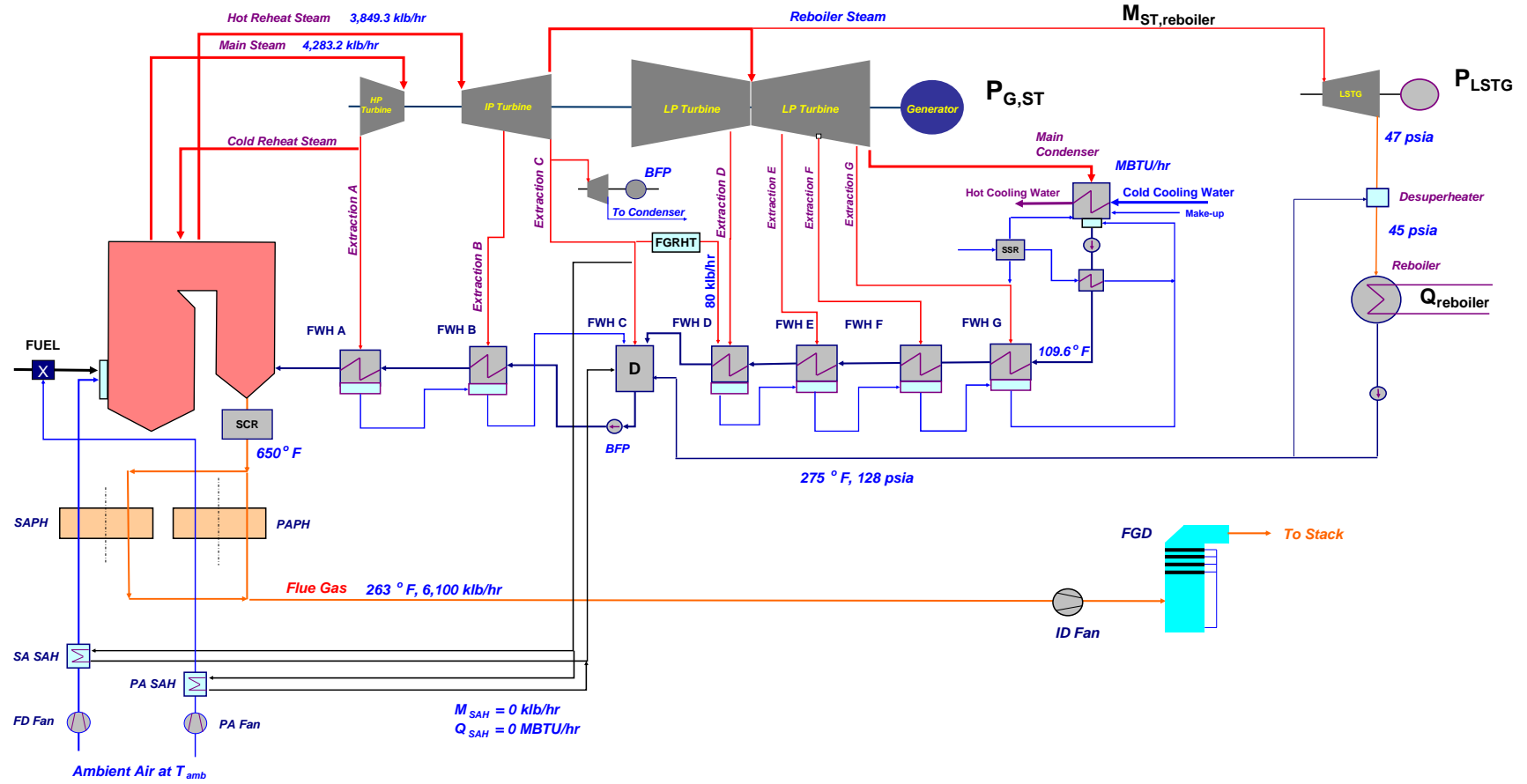

Case 2: Advanced Reboiler Integration with Steam Turbine Cycle

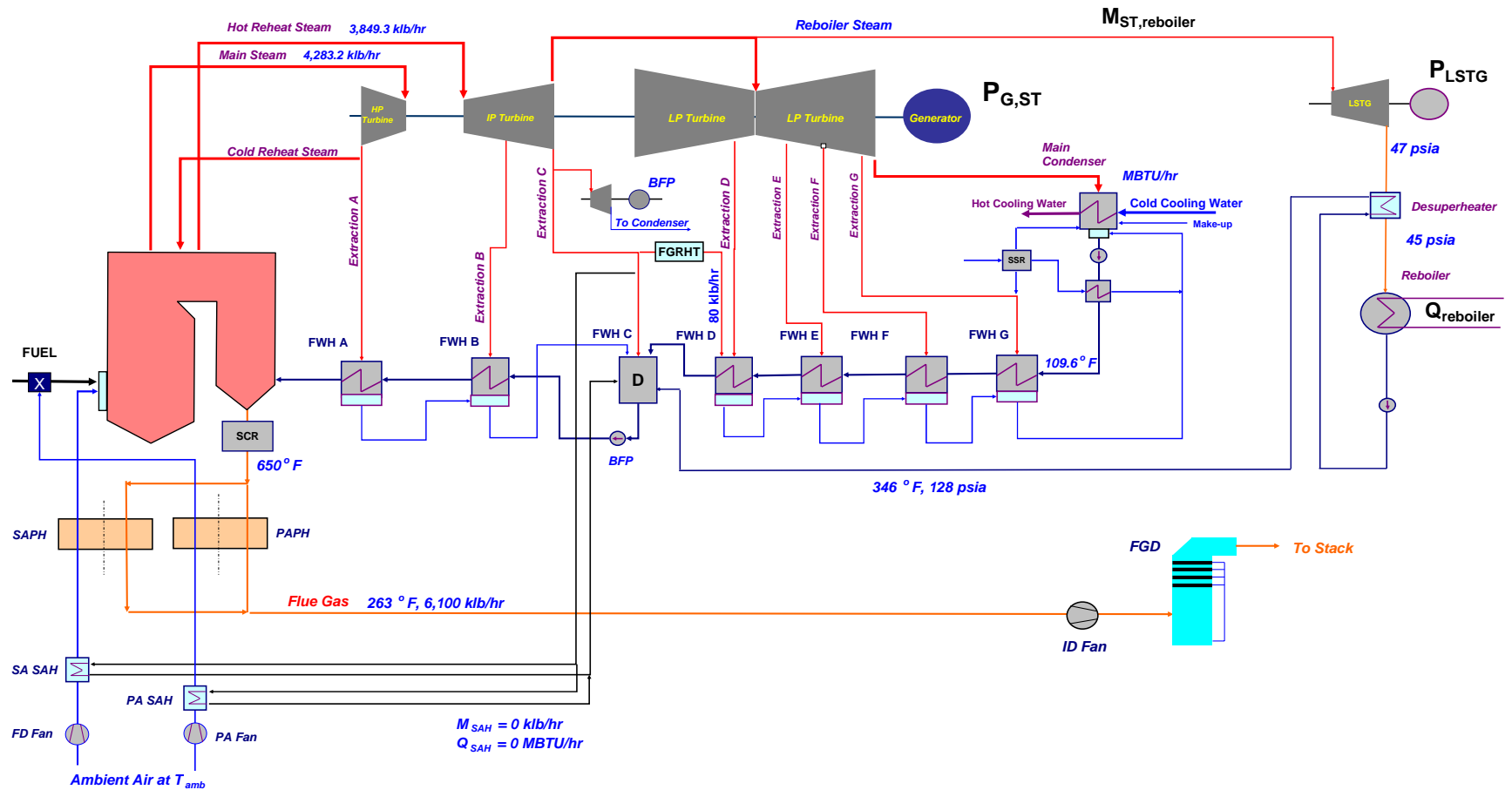

Case 3: Integration of Reboiler and CO₂ Compression with Steam Turbine Cycle

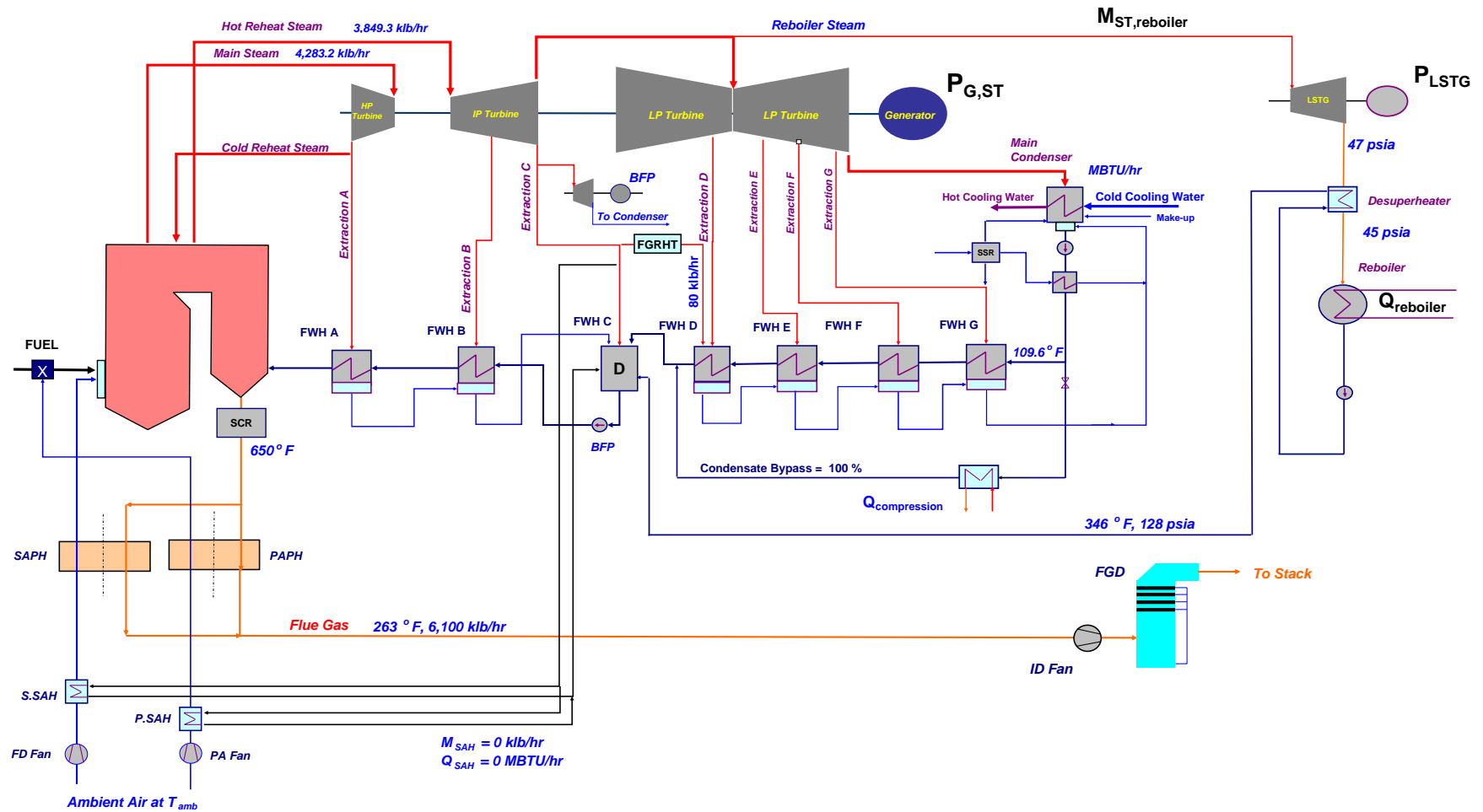

Case 4: Integration of Boiler, Reboiler and CO₂ Compression with Steam Turbine Cycle

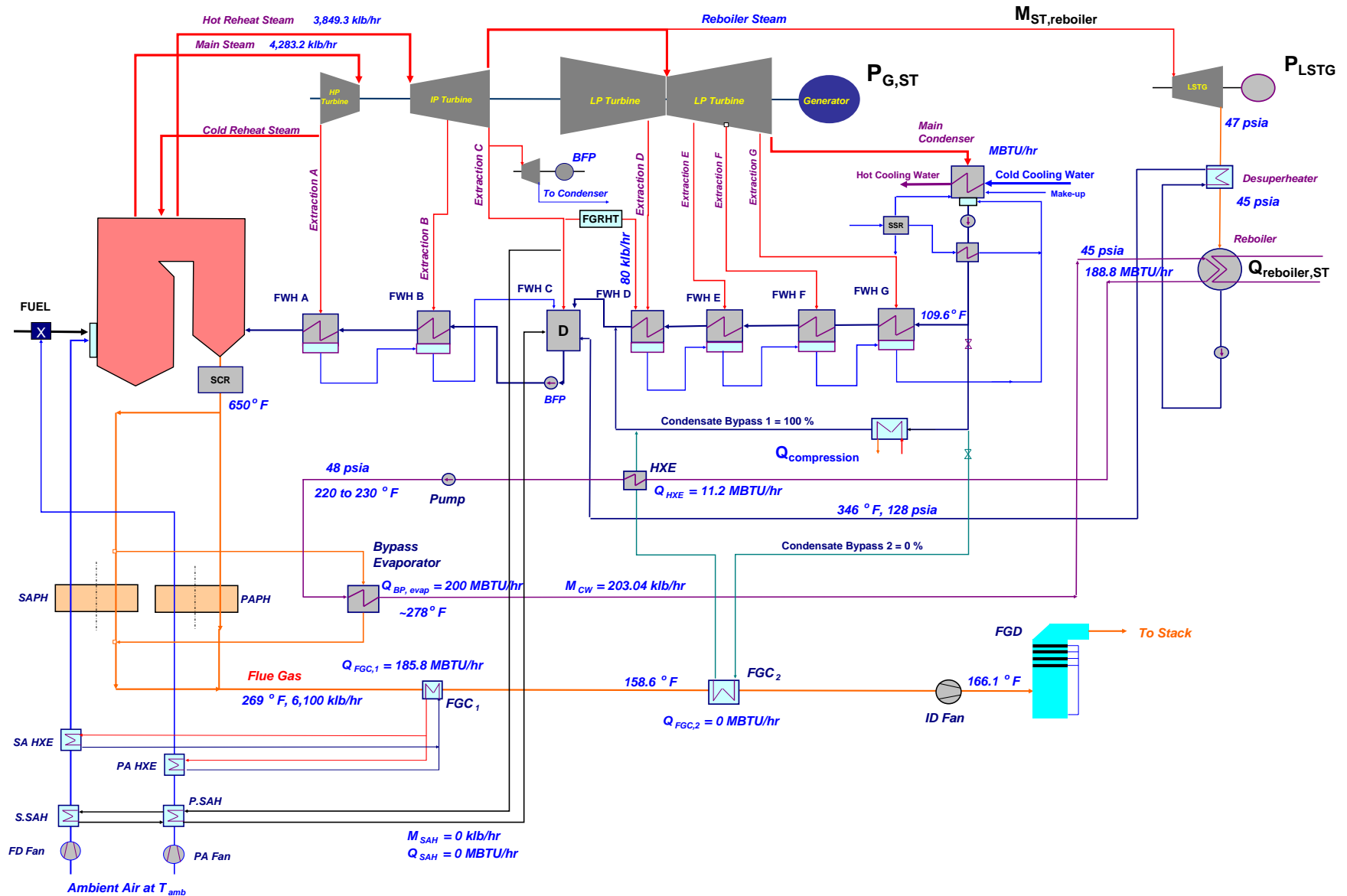

Case 4a: Integration of Boiler, Reboiler and CO₂ Compression with Steam Turbine Cycle

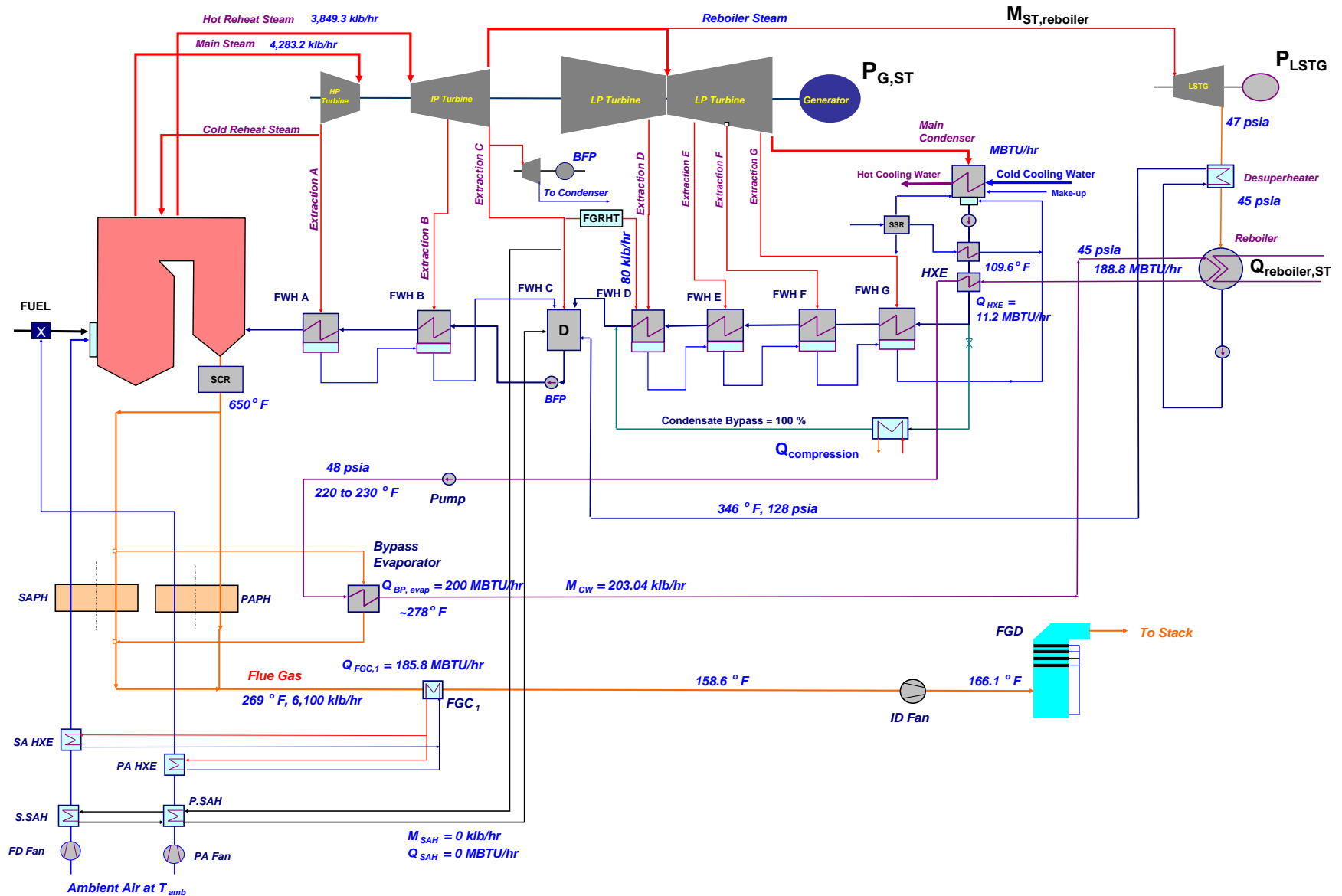

Case 5: Integration of Boiler and Reboiler with Steam Turbine Cycle

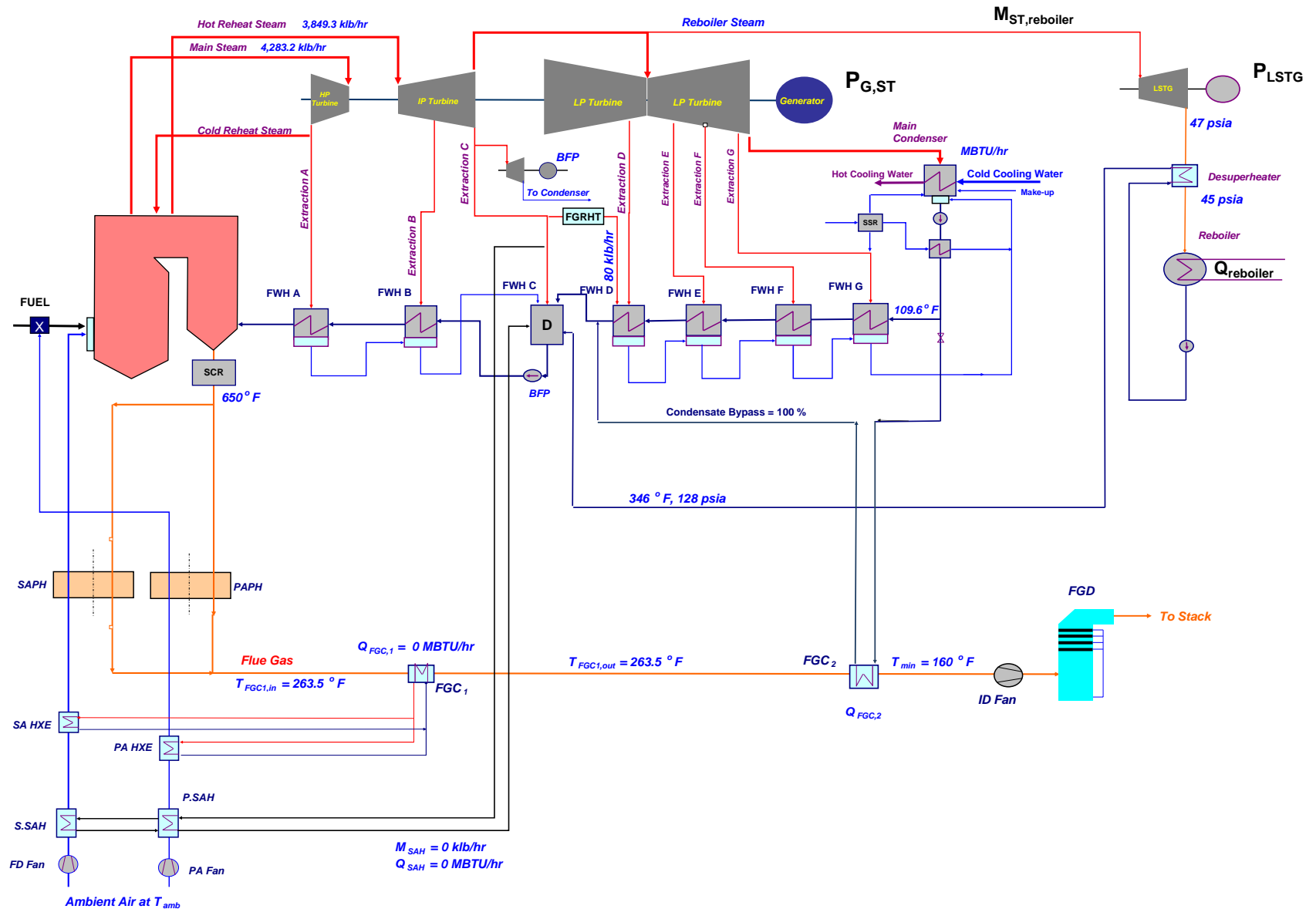

Case 6: Integration of Boiler, Reboiler and CO₂ Compression with Steam Turbine Cycle

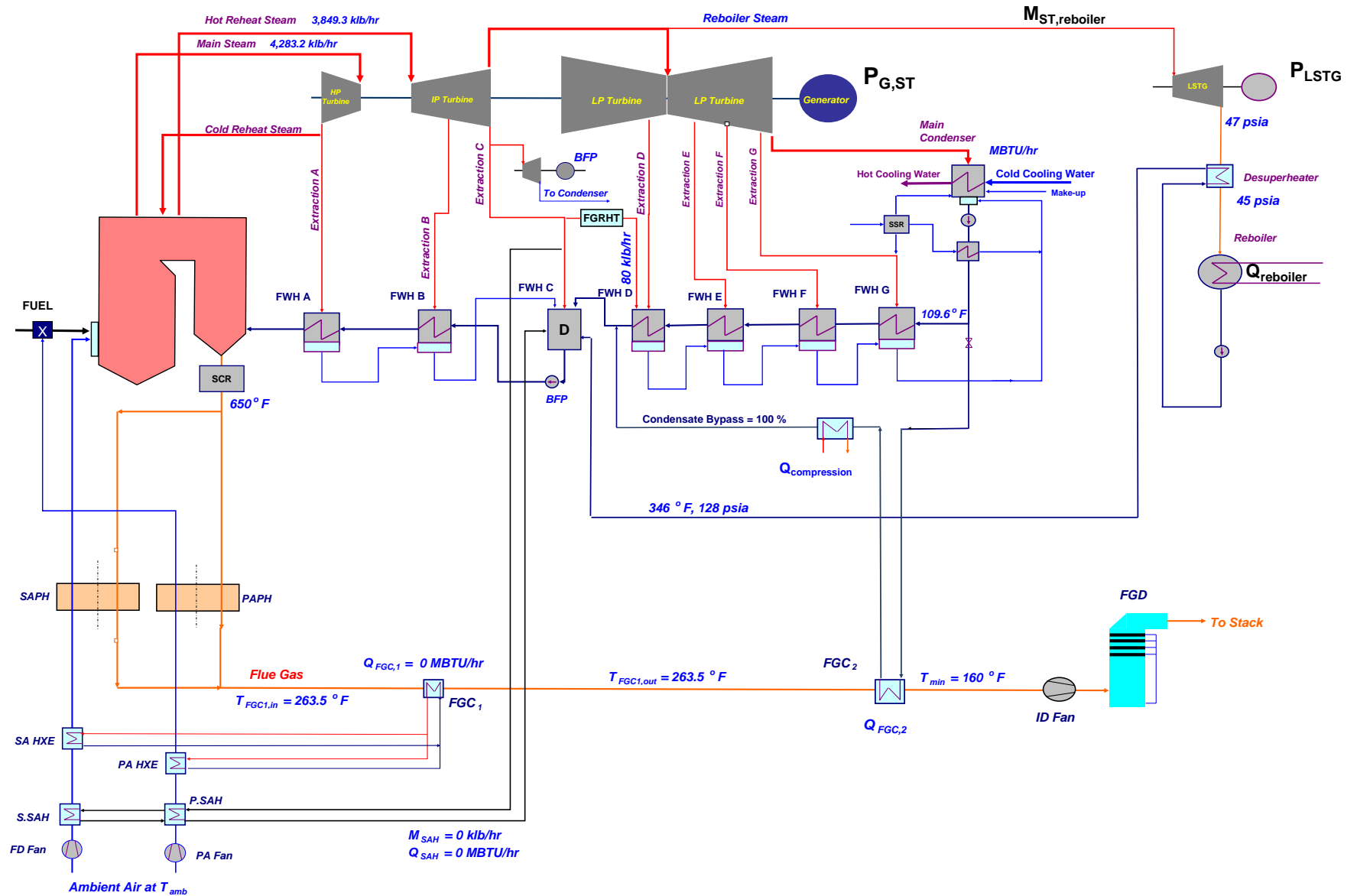

Results for $q_{reb} = 2,000 \text{ BTU/lb}$

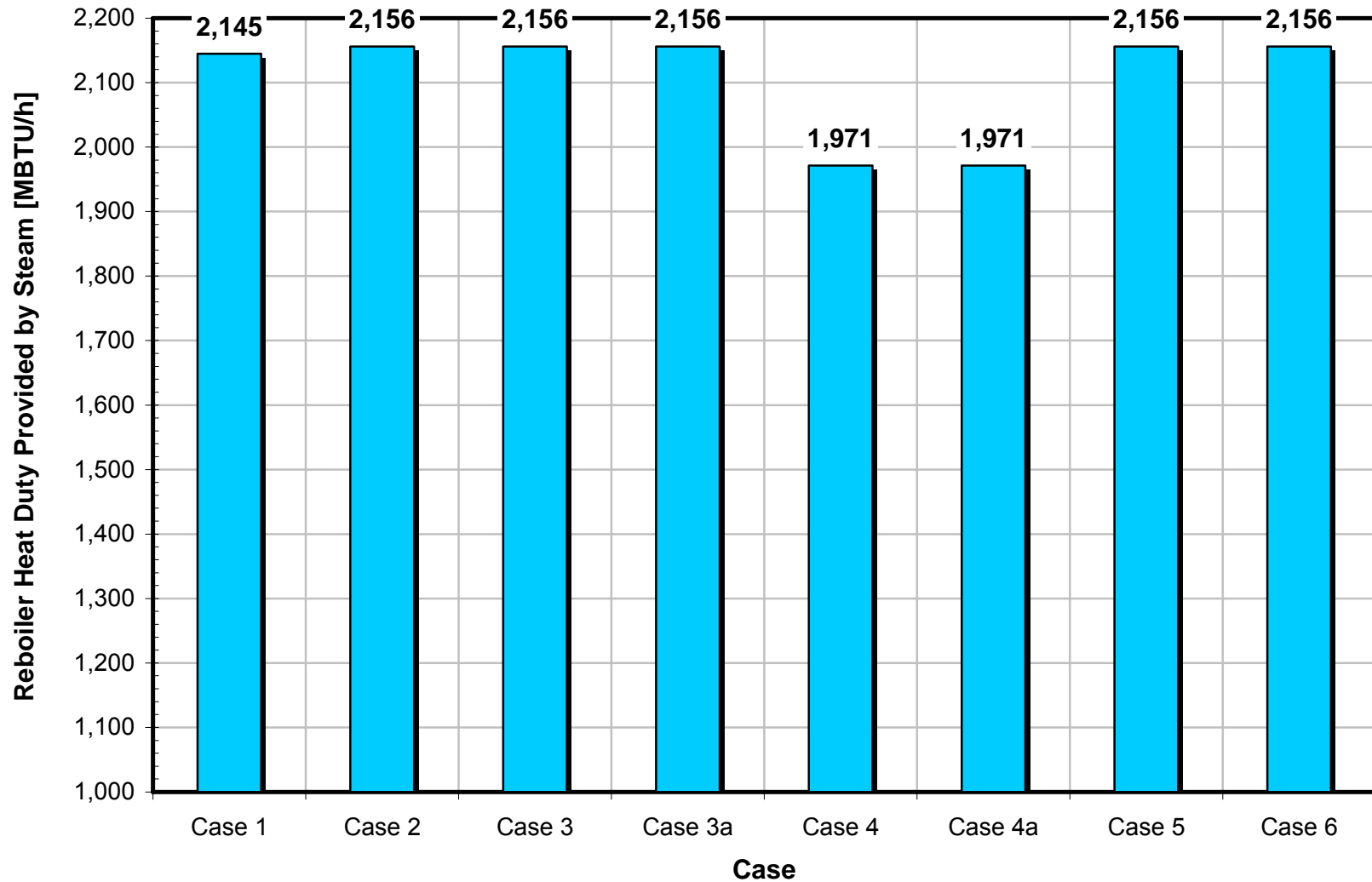

Results for $q_{reb} = 2,000 \text{ BTU/lb}$

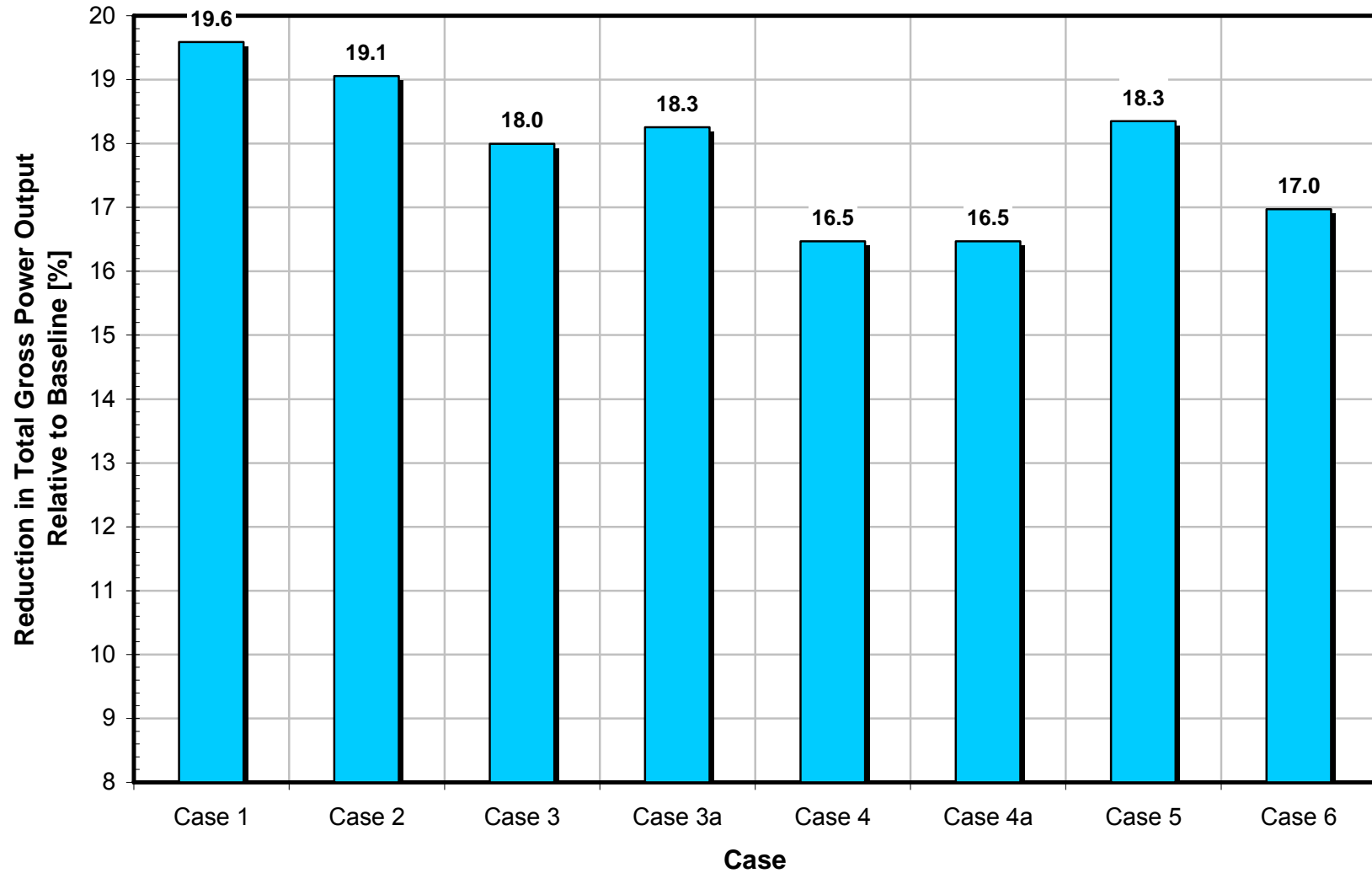

Results for $q_{reb} = 2,000 \text{ BTU/lb}$

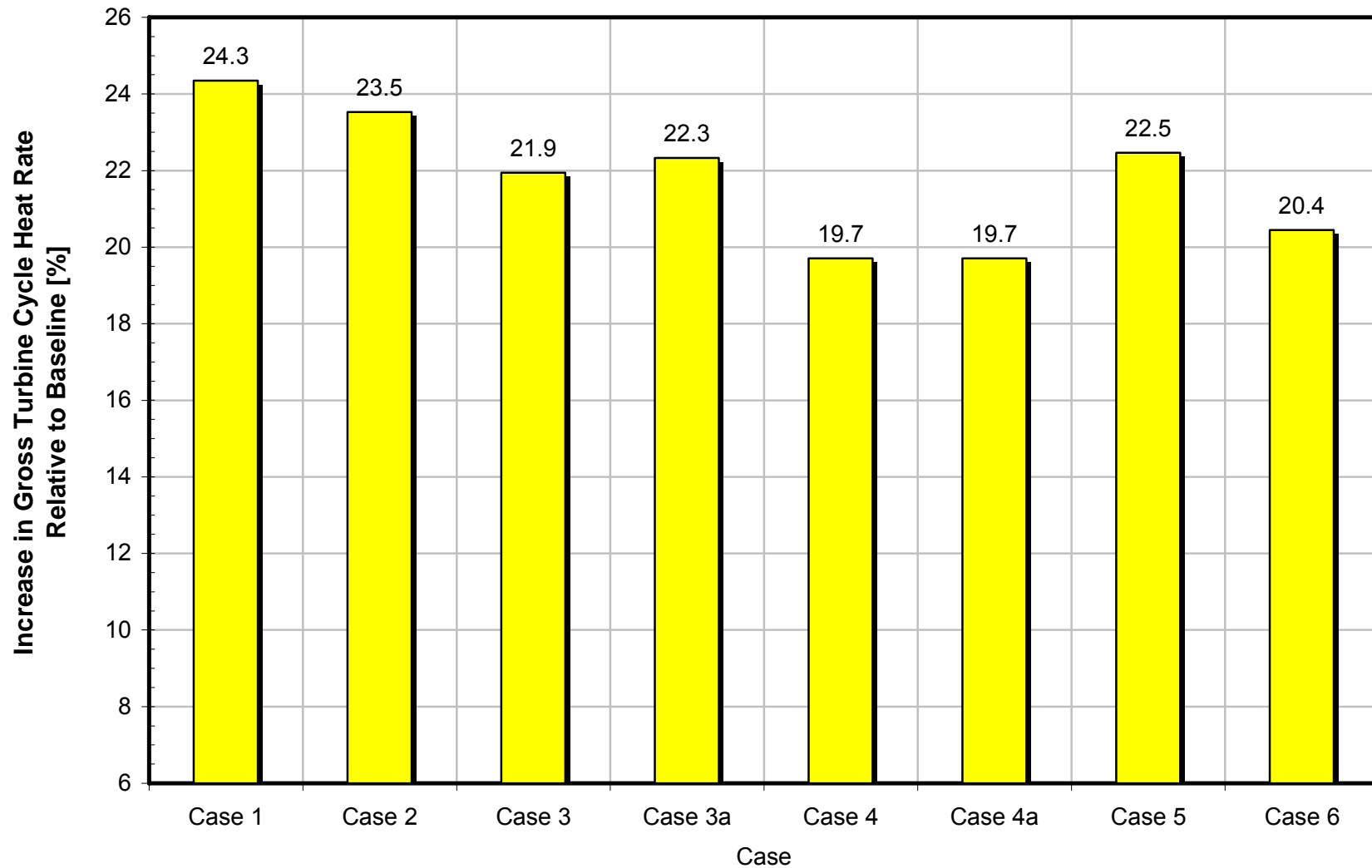

Results for $q_{reb} = 2,000 \text{ BTU/lb}$

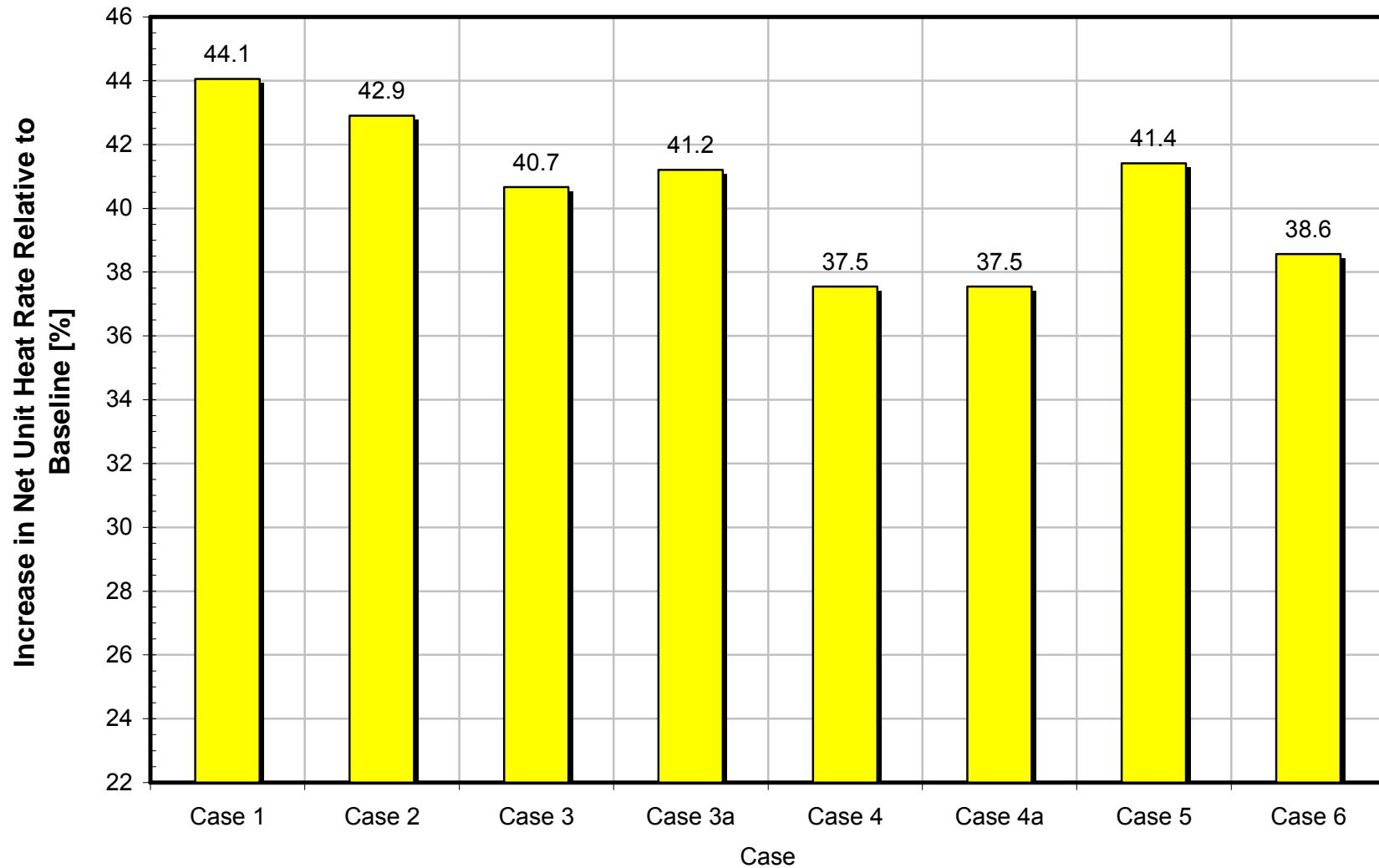

Results for $q_{reb} = 2,000 \text{ BTU/lb}$

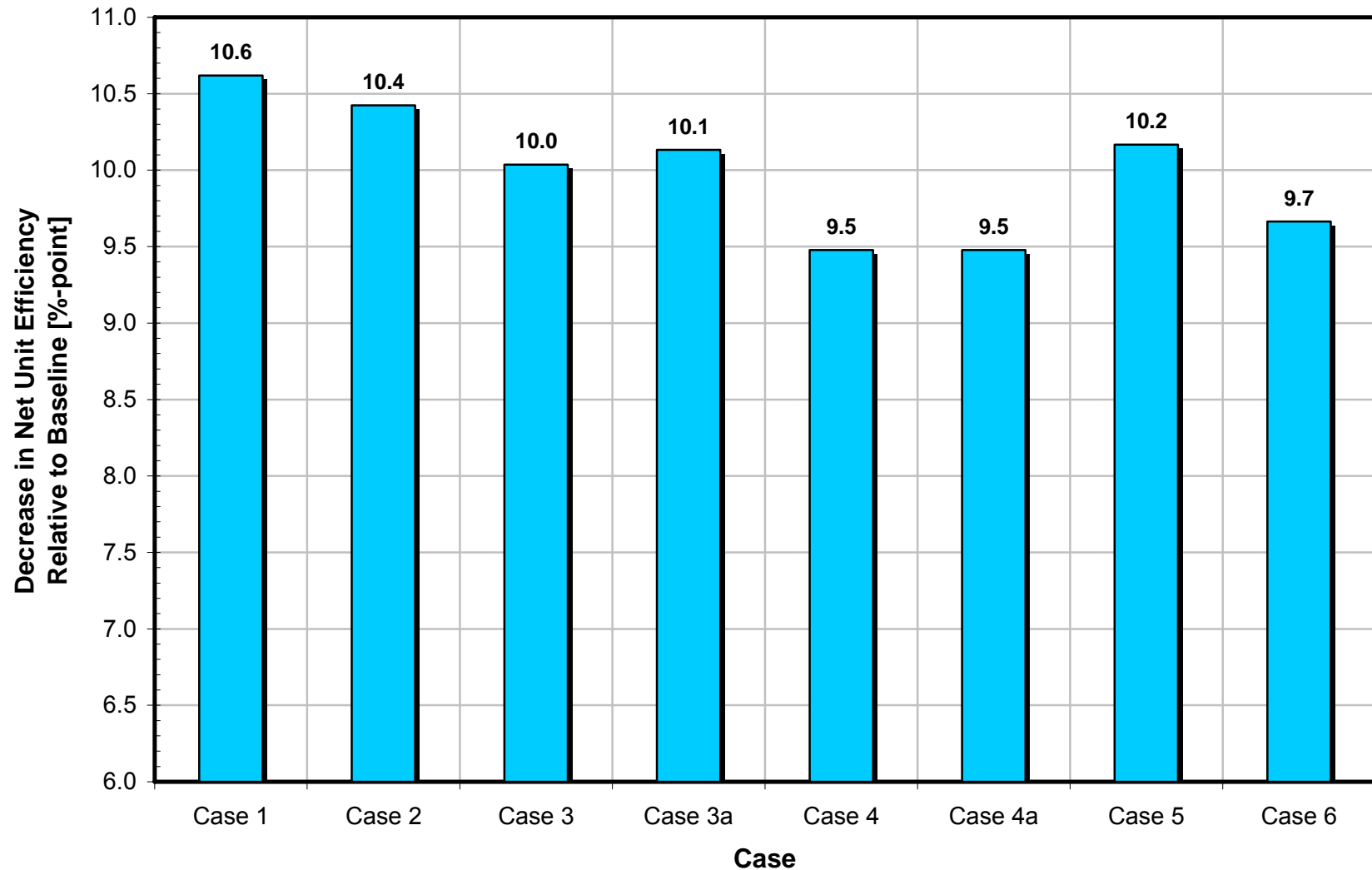

Results for $q_{reb} = 2,000 \text{ BTU/lb}$

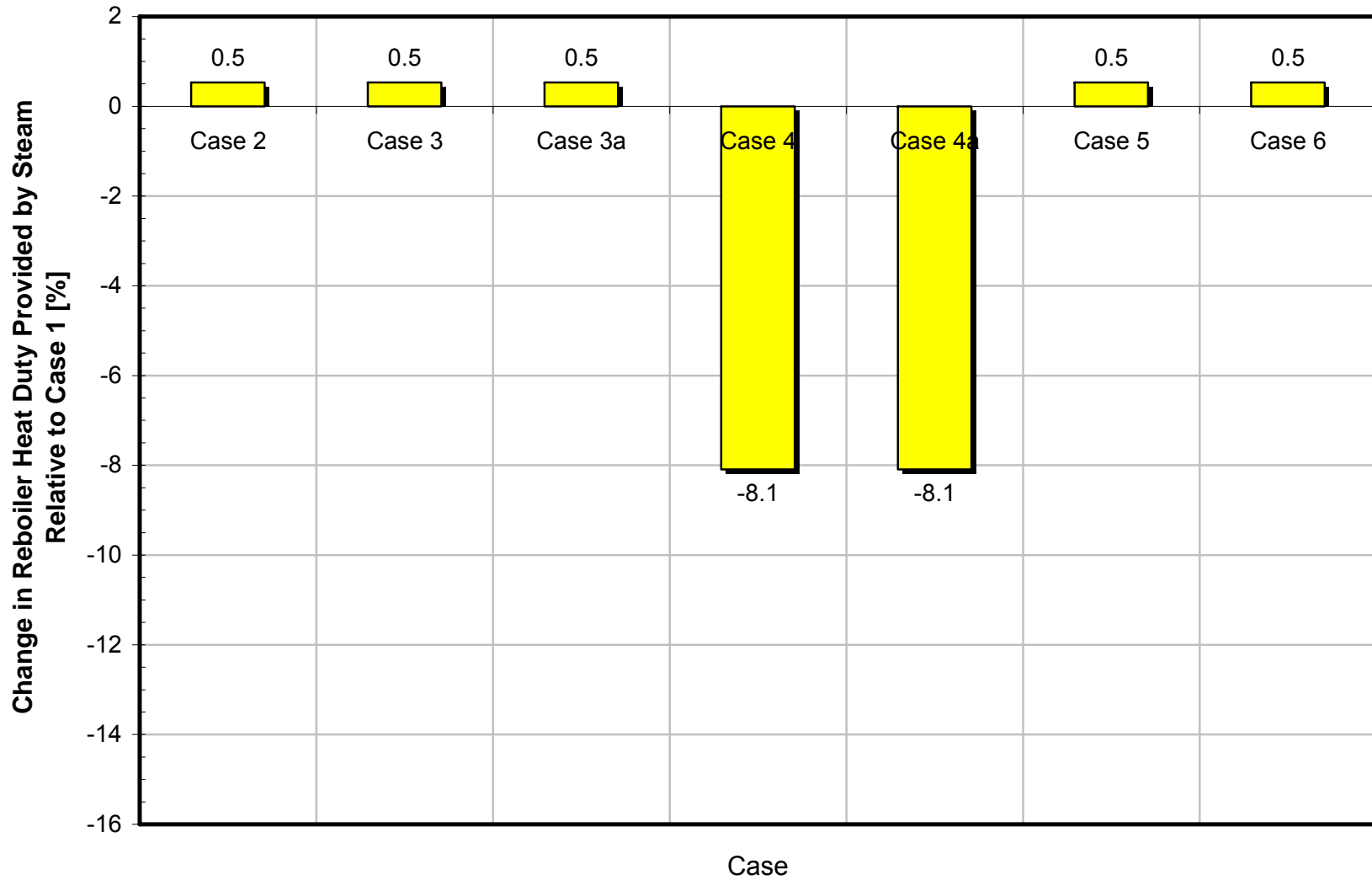

Results for $q_{reb} = 2,000 \text{ BTU/lb}$

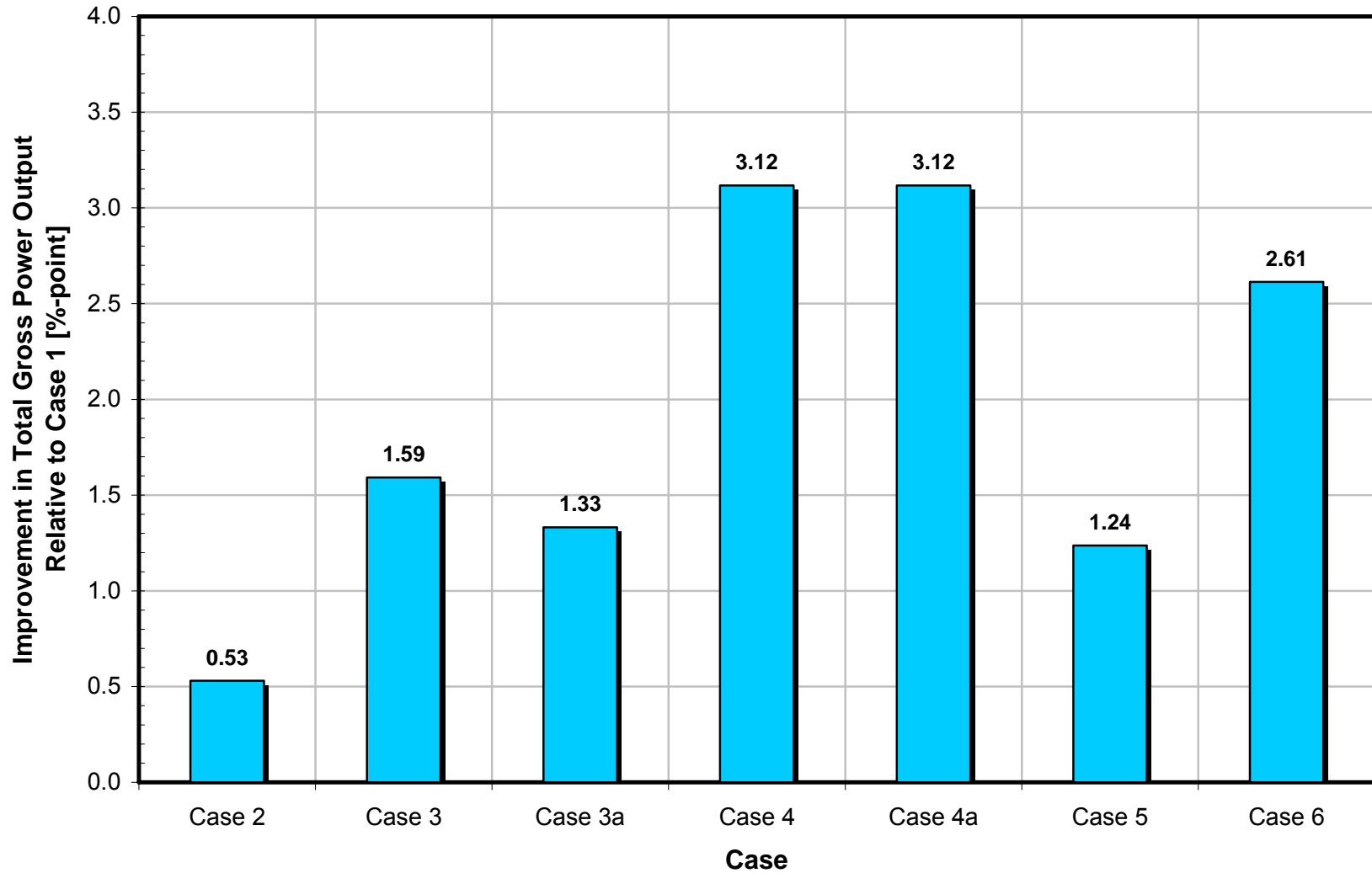

Results for $q_{reb} = 2,000 \text{ BTU/lb}$

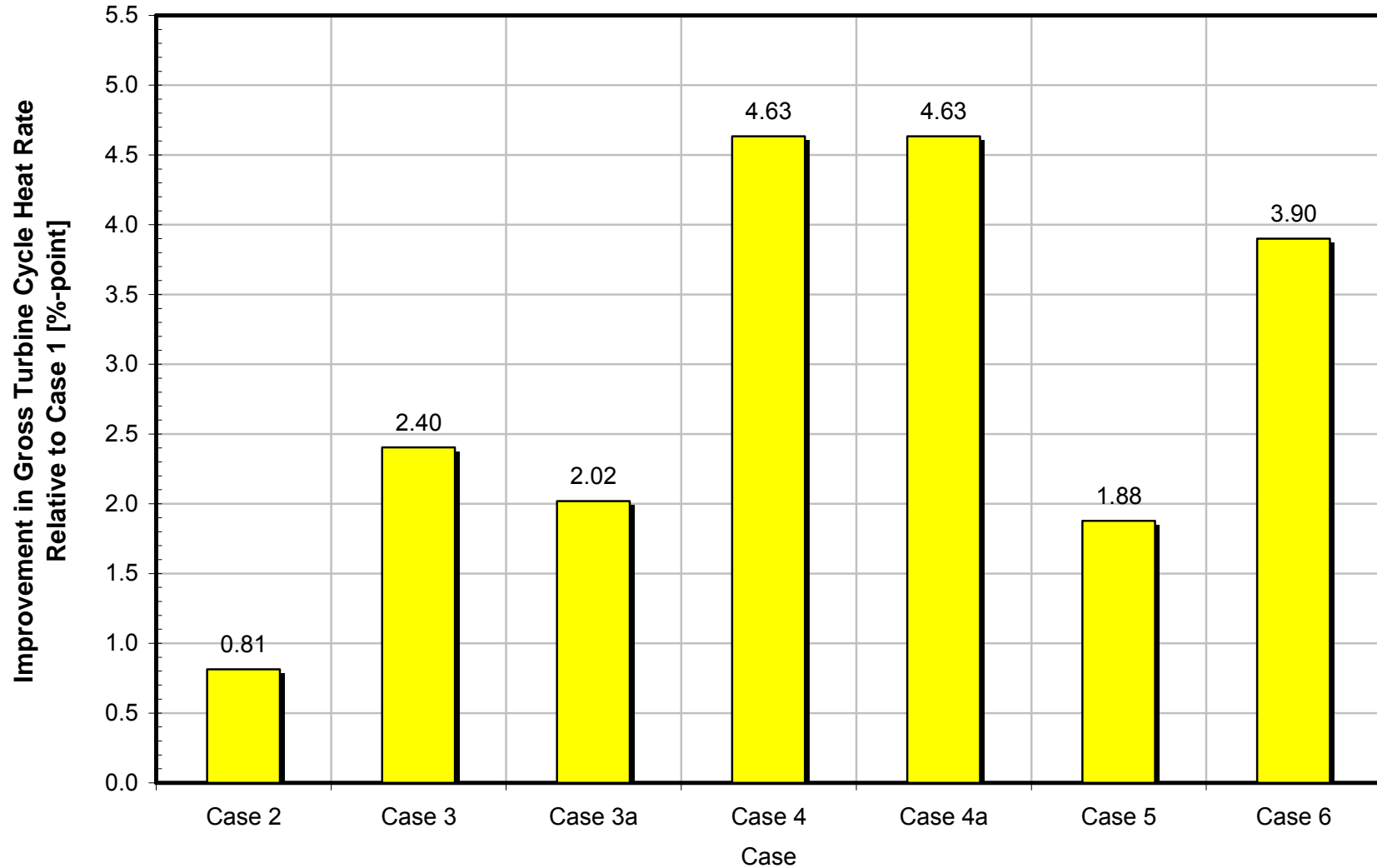

Results for $q_{reb} = 2,000 \text{ BTU/lb}$

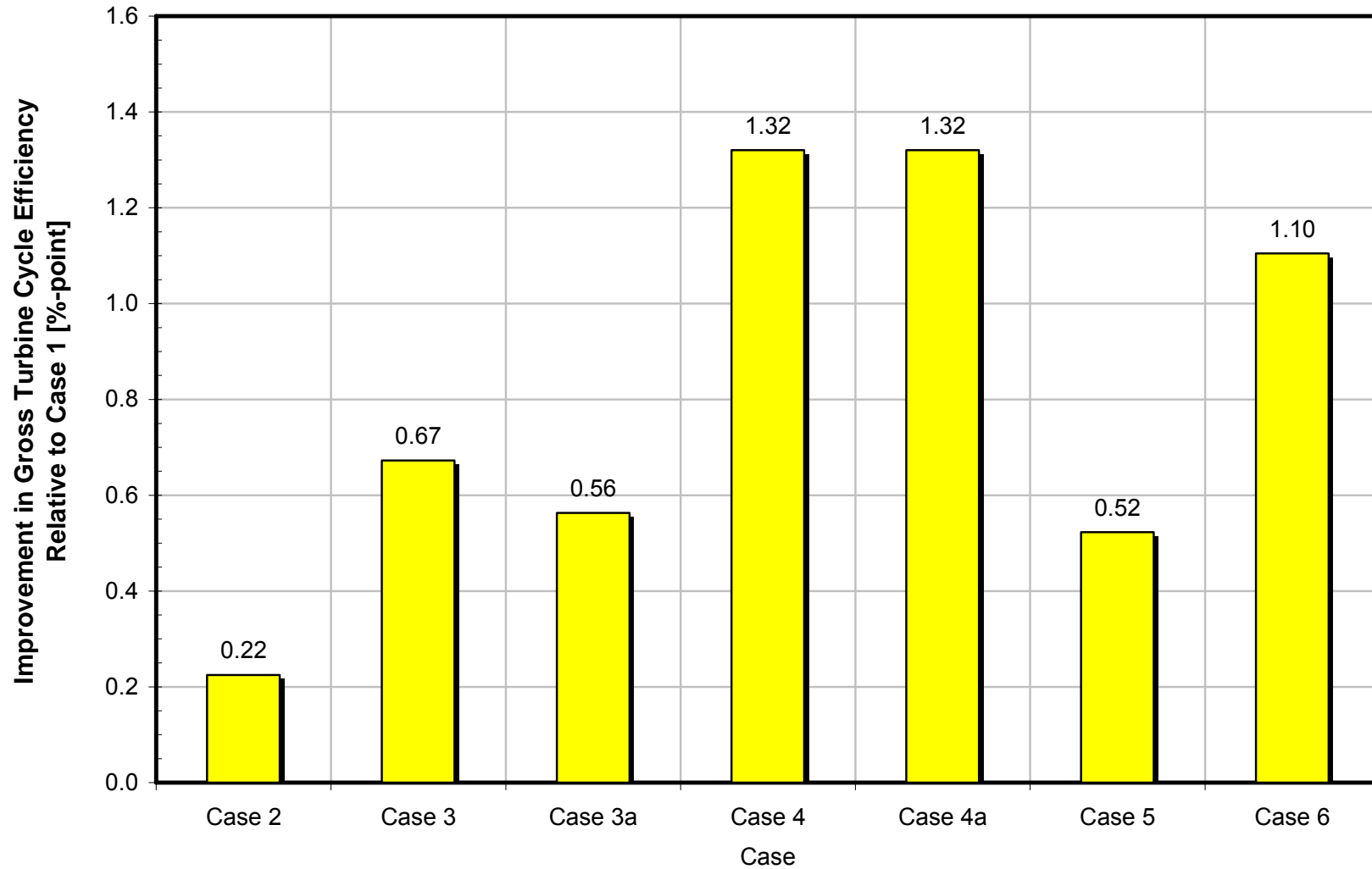

Results for $q_{reb} = 2,000 \text{ BTU/lb}$

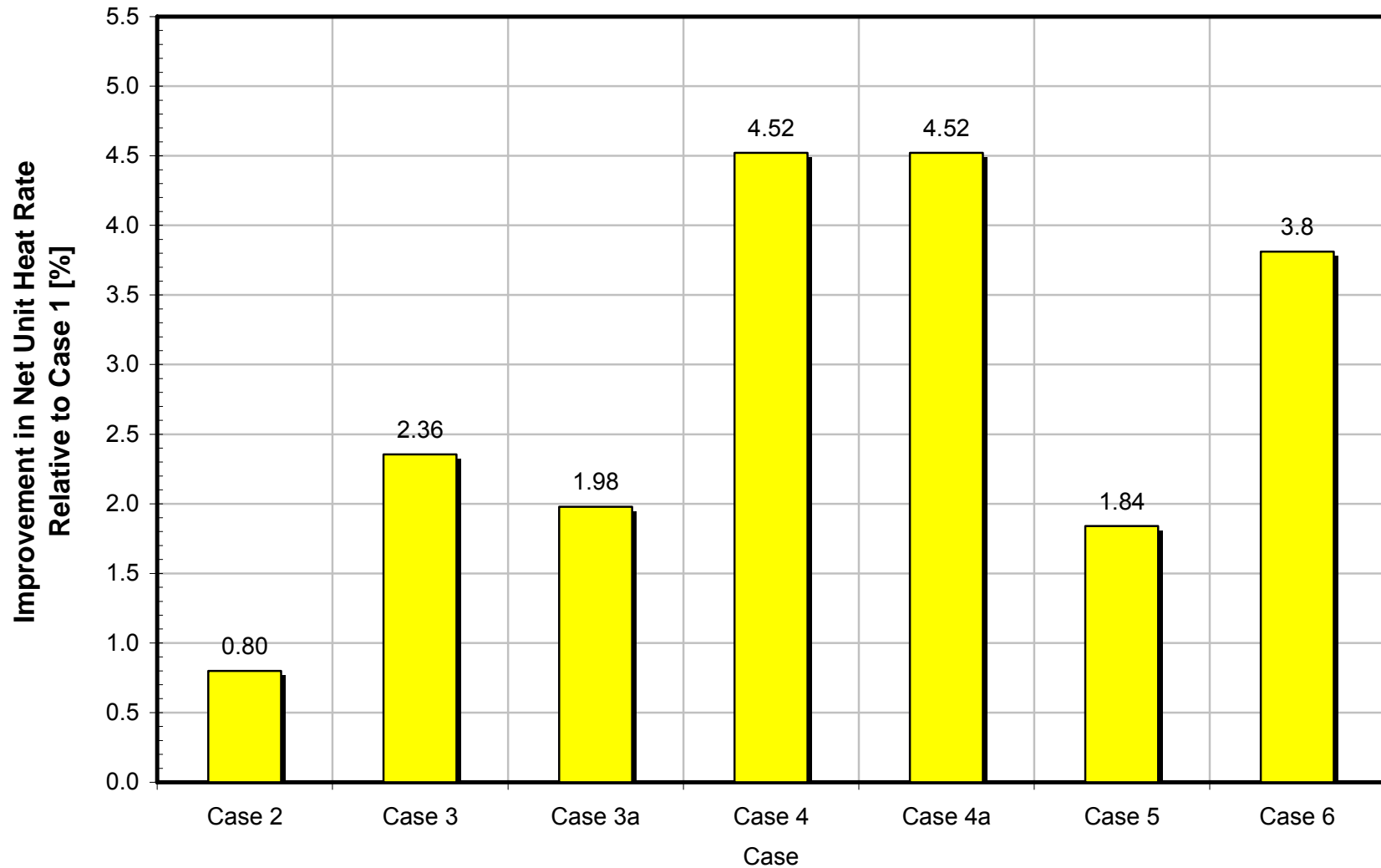

Results for $q_{reb} = 2,000 \text{ BTU/lb}$

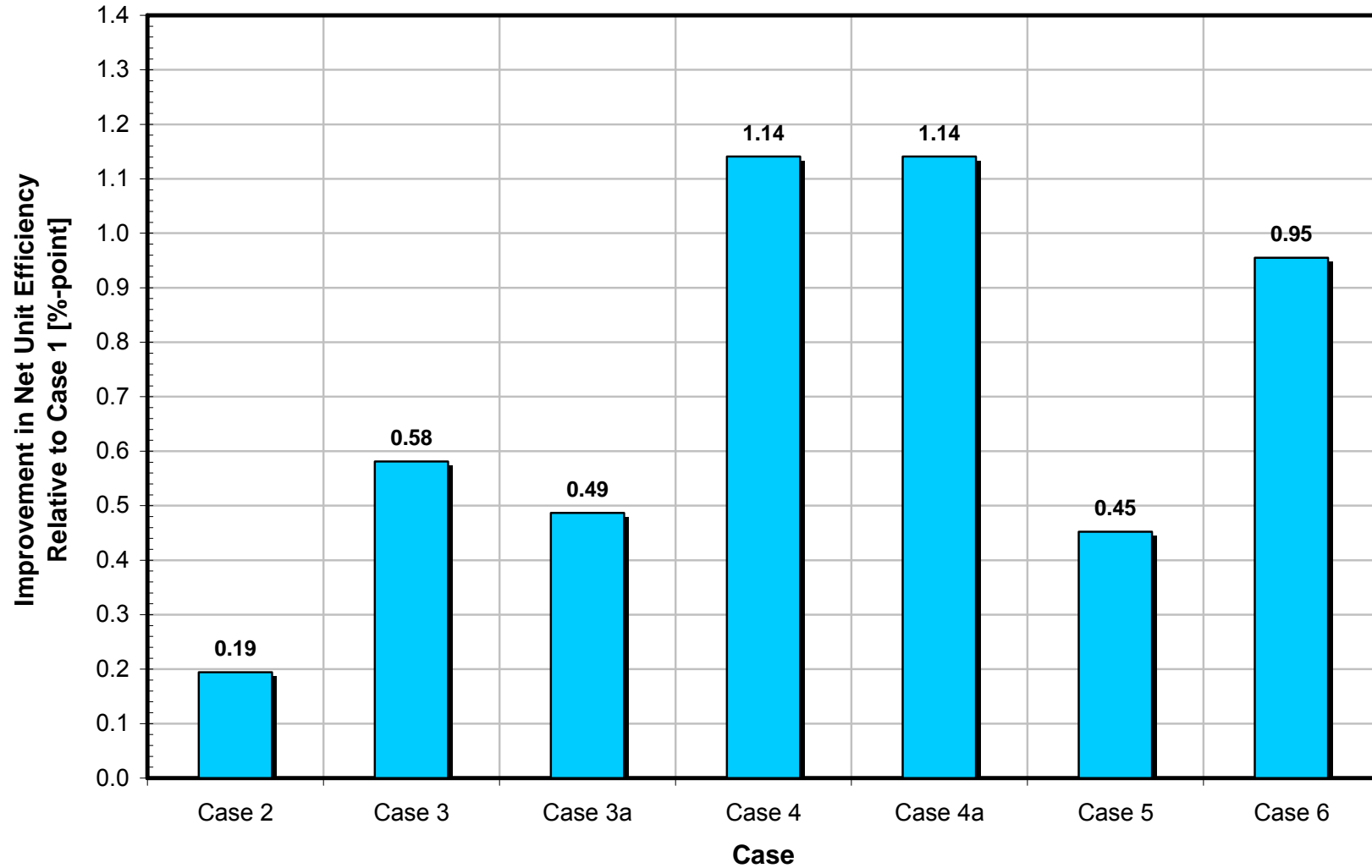

Summary of Results

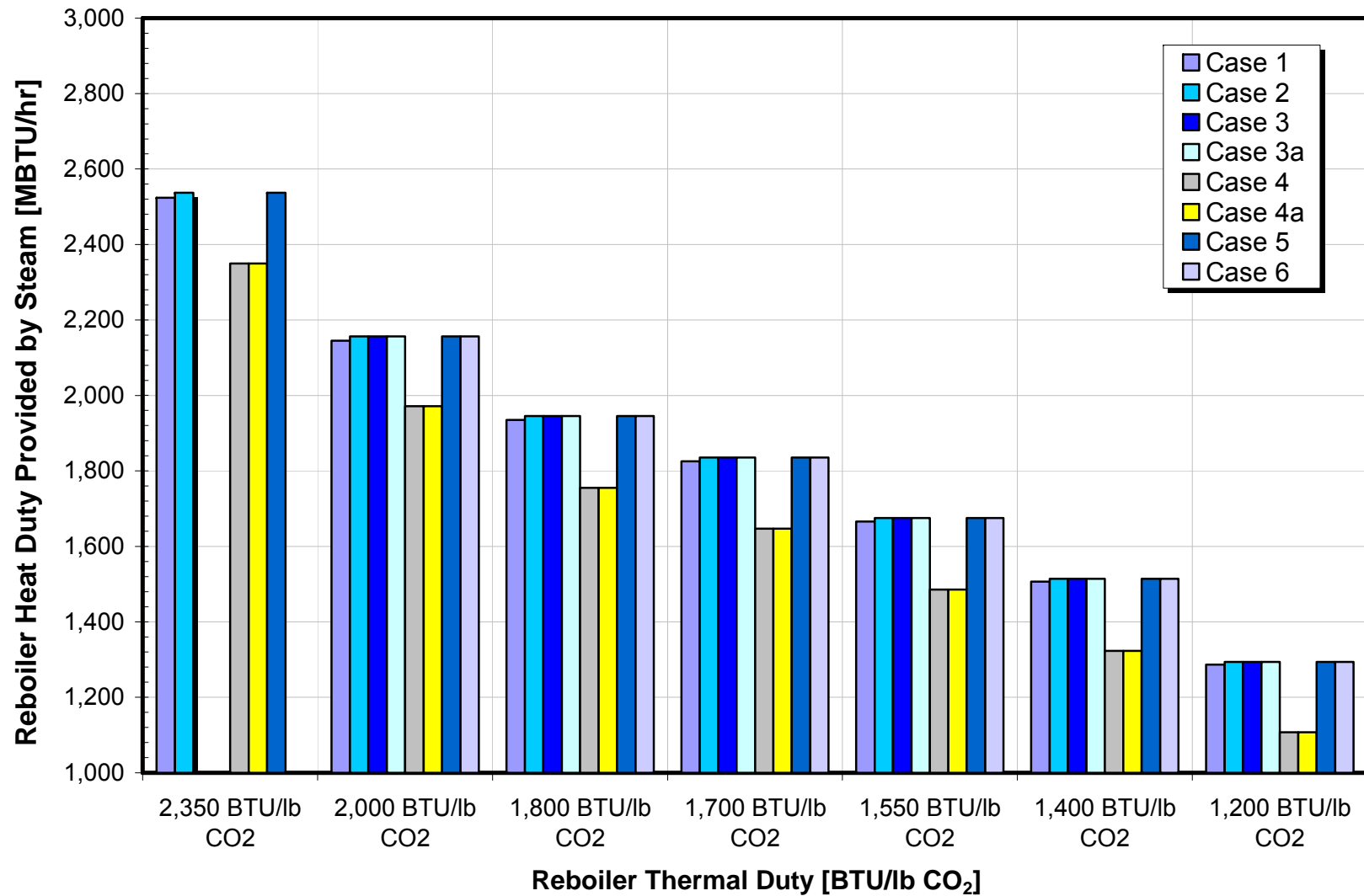

Summary of Results

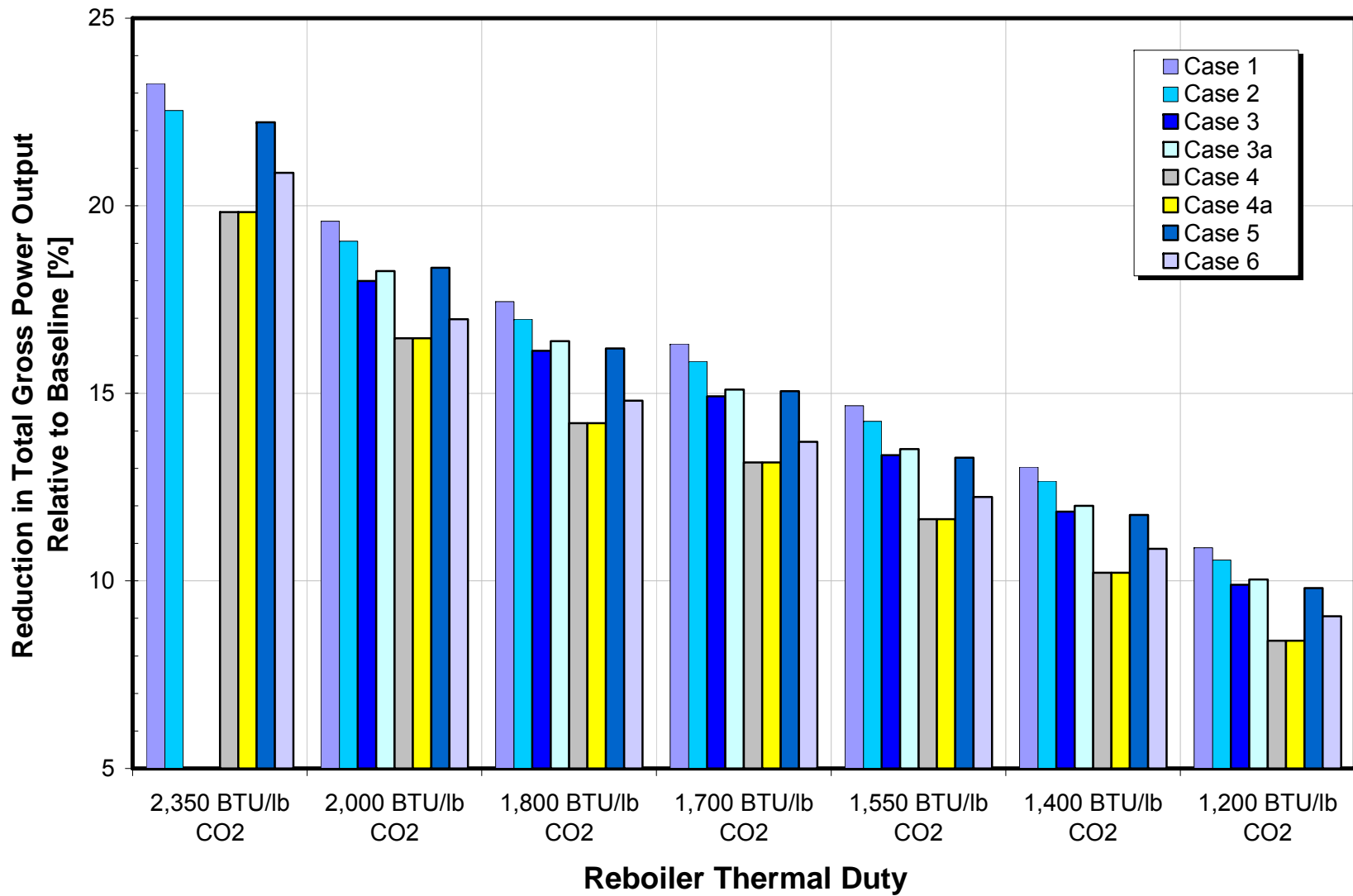

Summary of Results

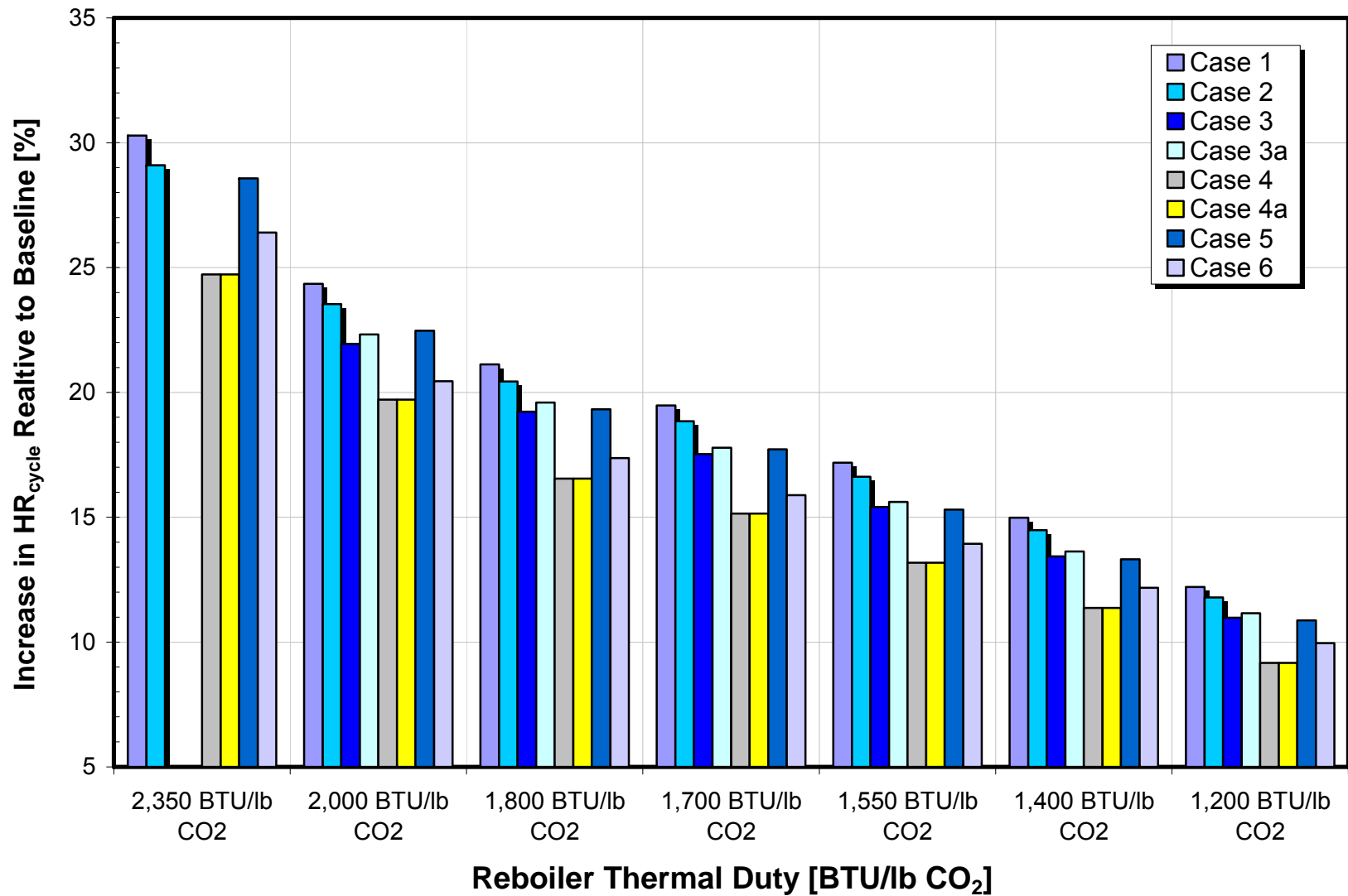

Summary of Results

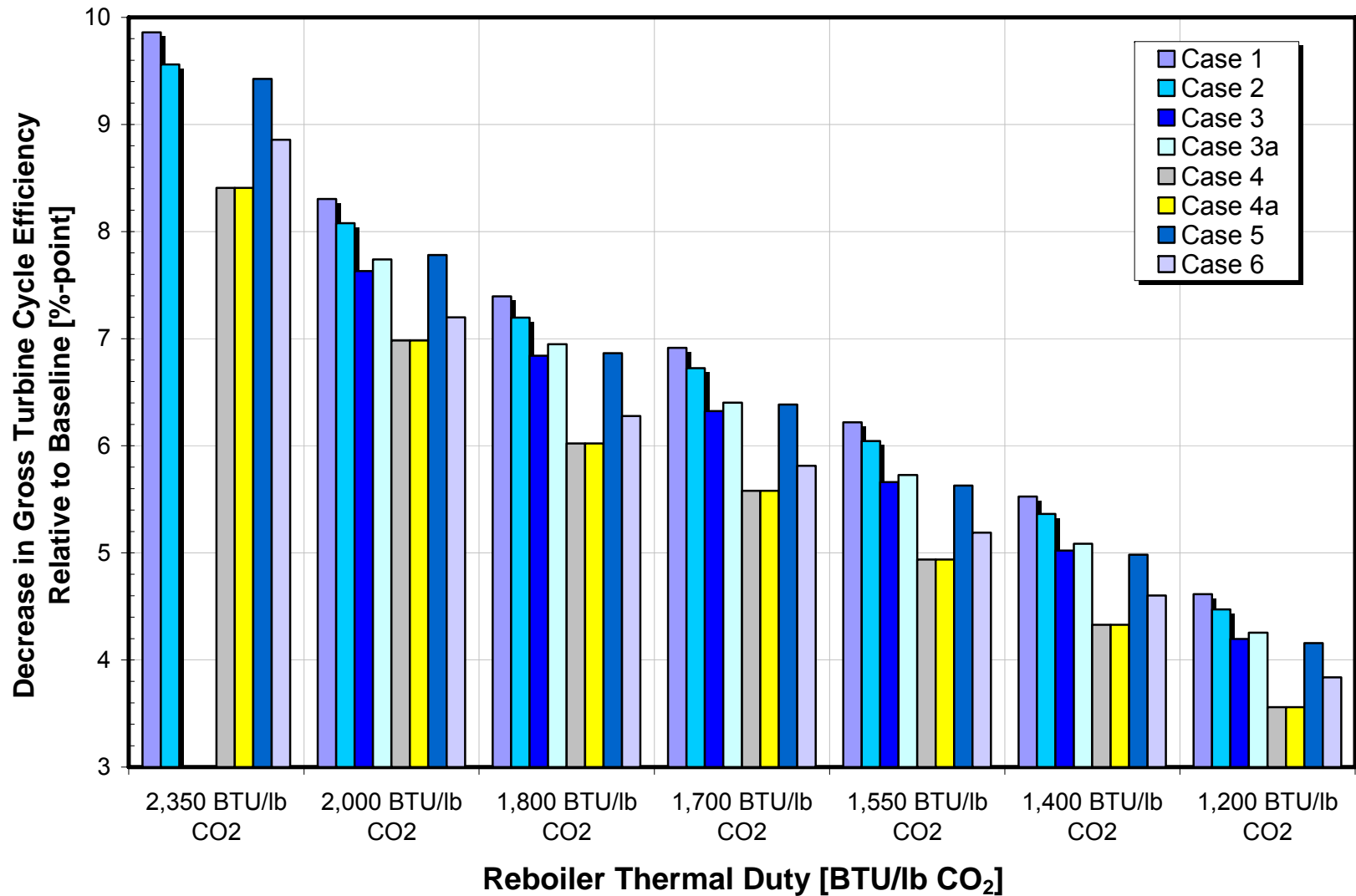

Summary of Results

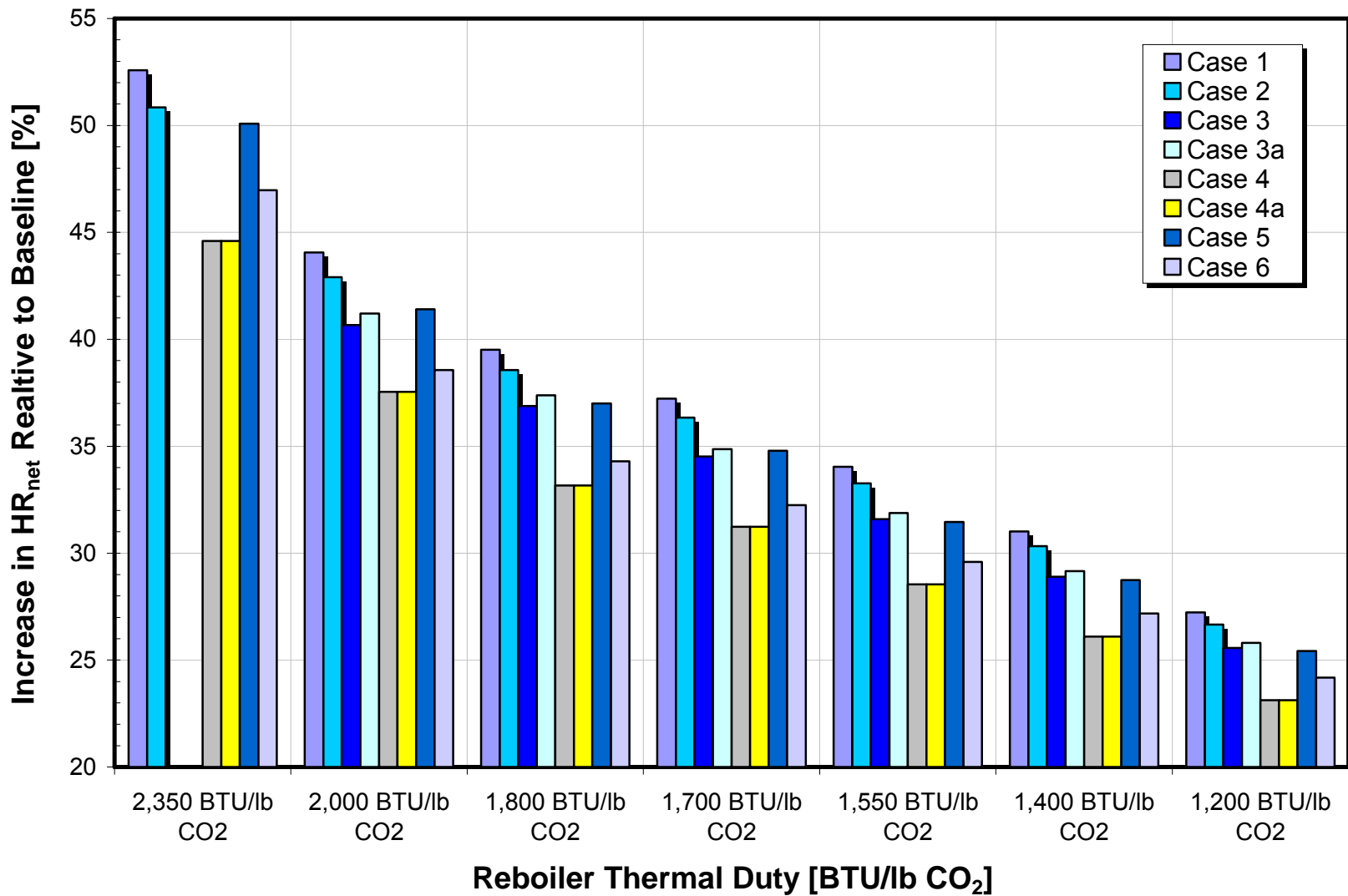

Summary of Results

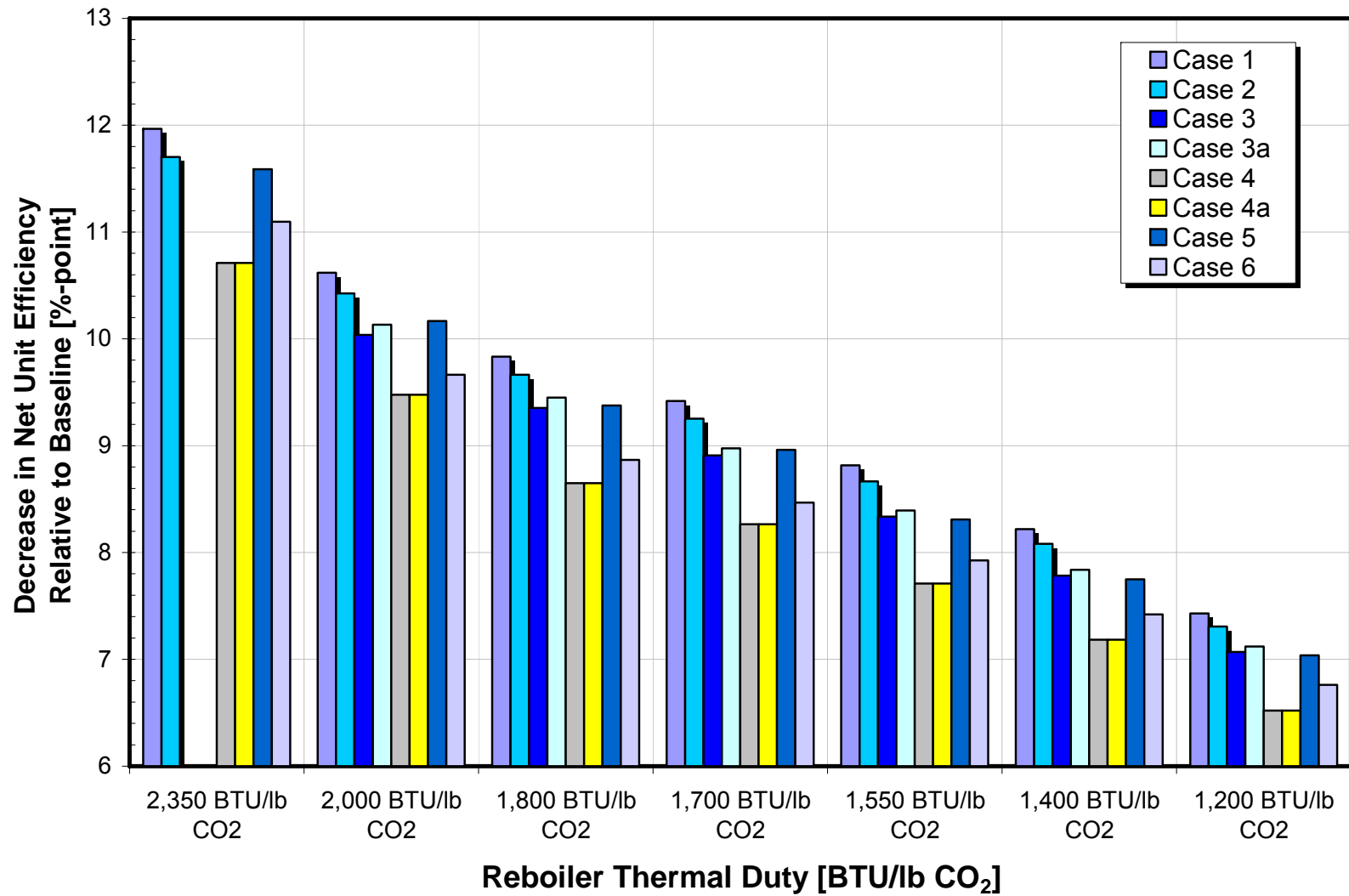

Summary of Results

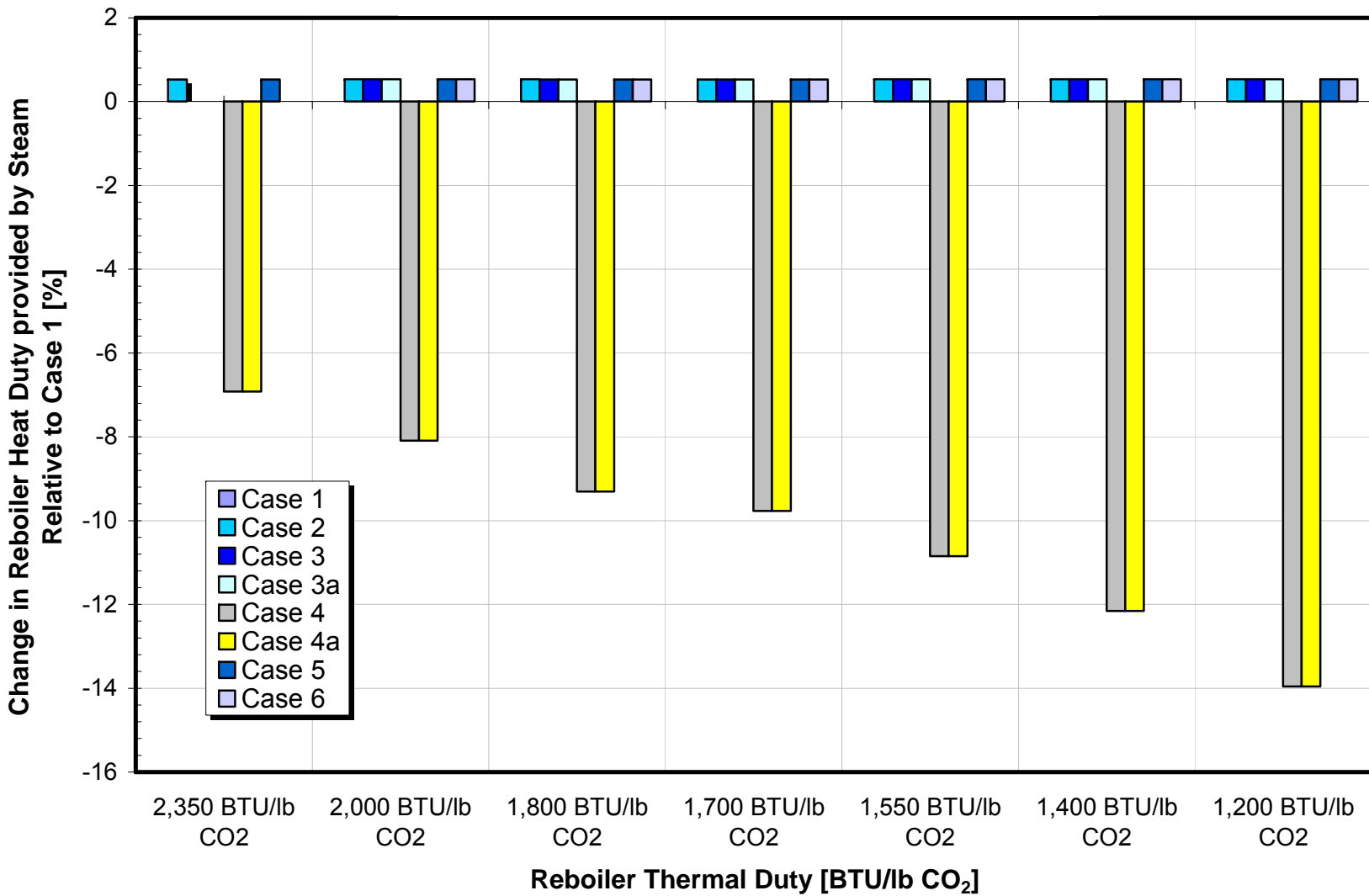

Summary of Results

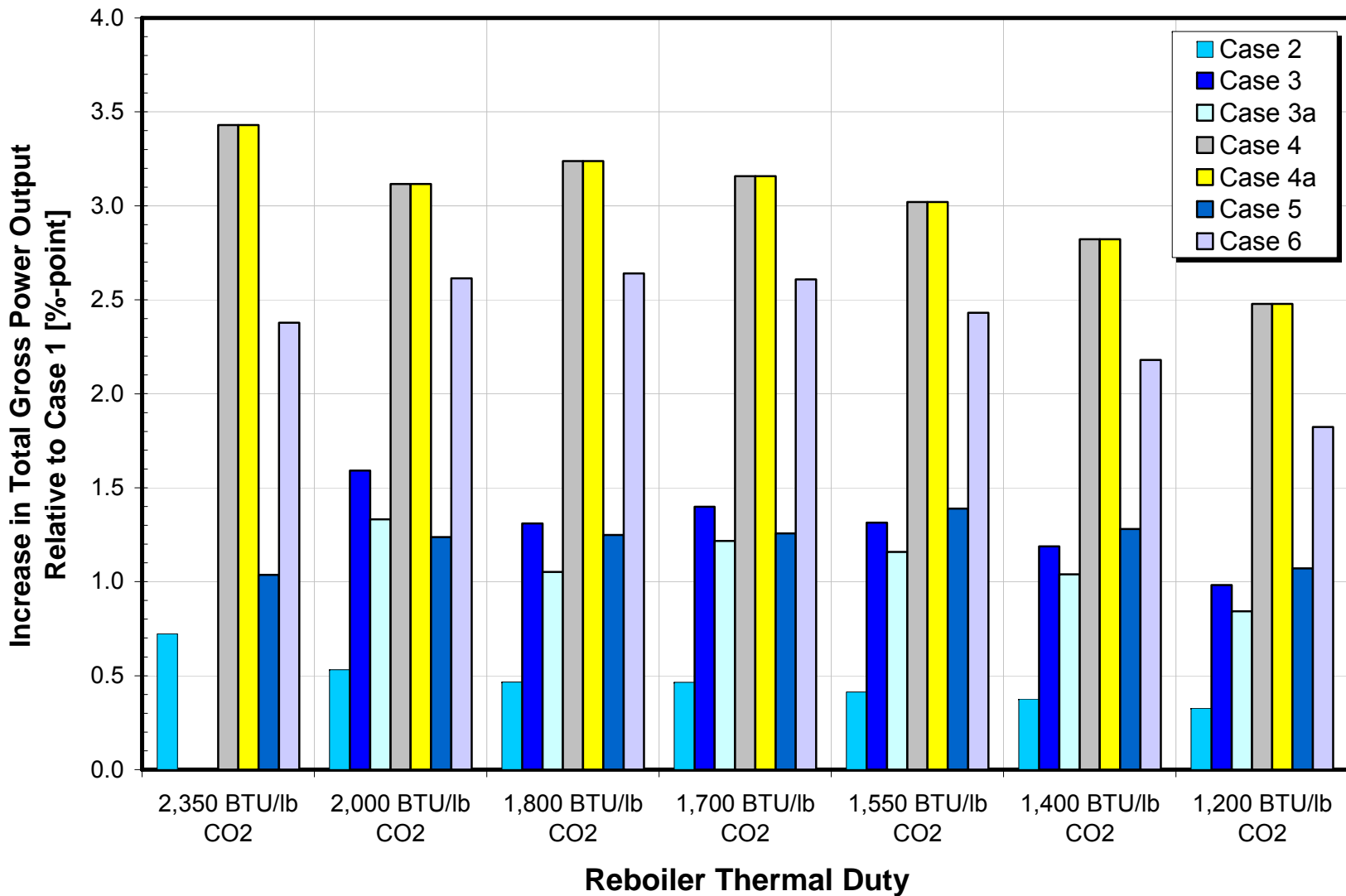

Summary of Results

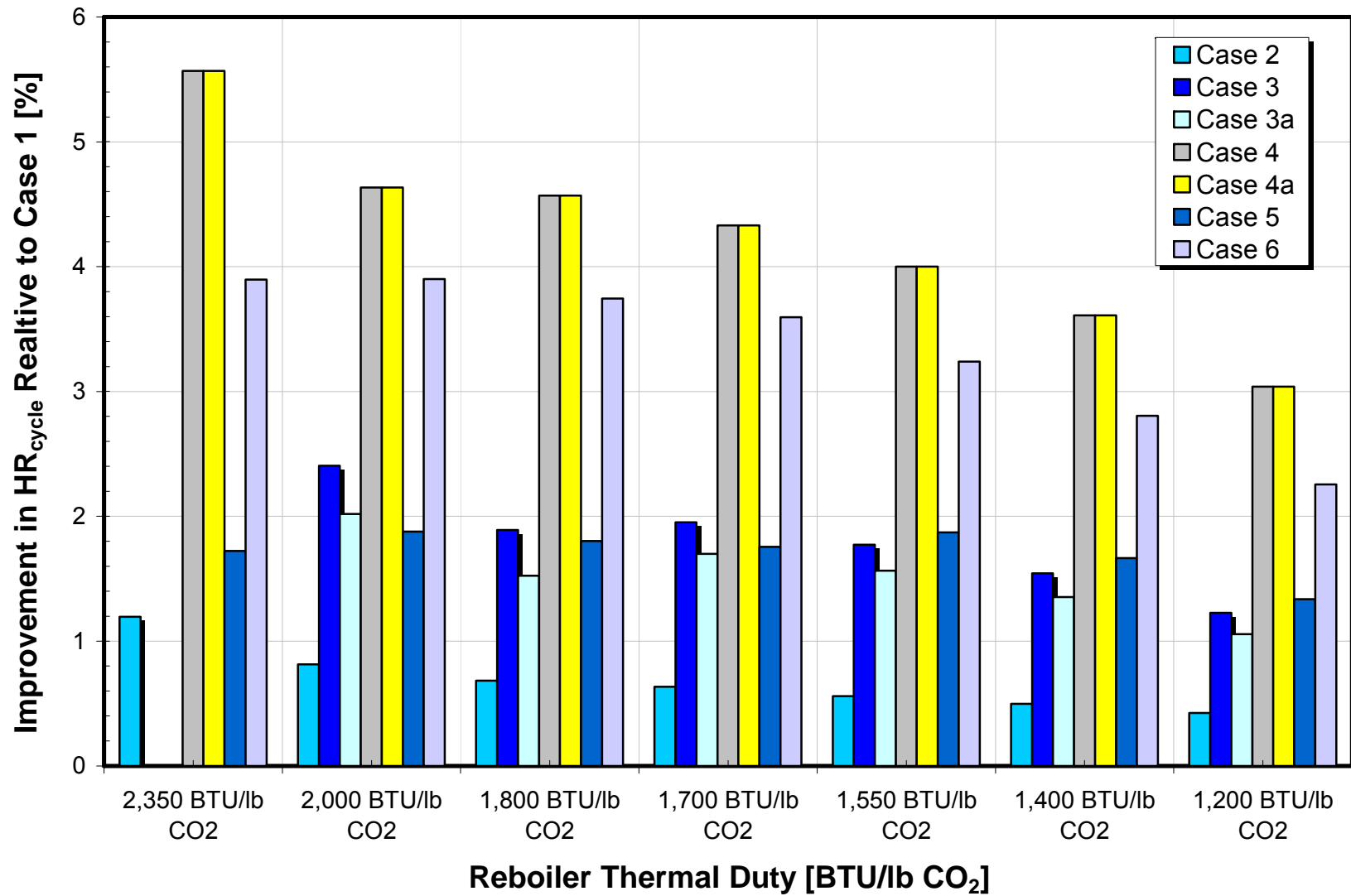

Summary of Results

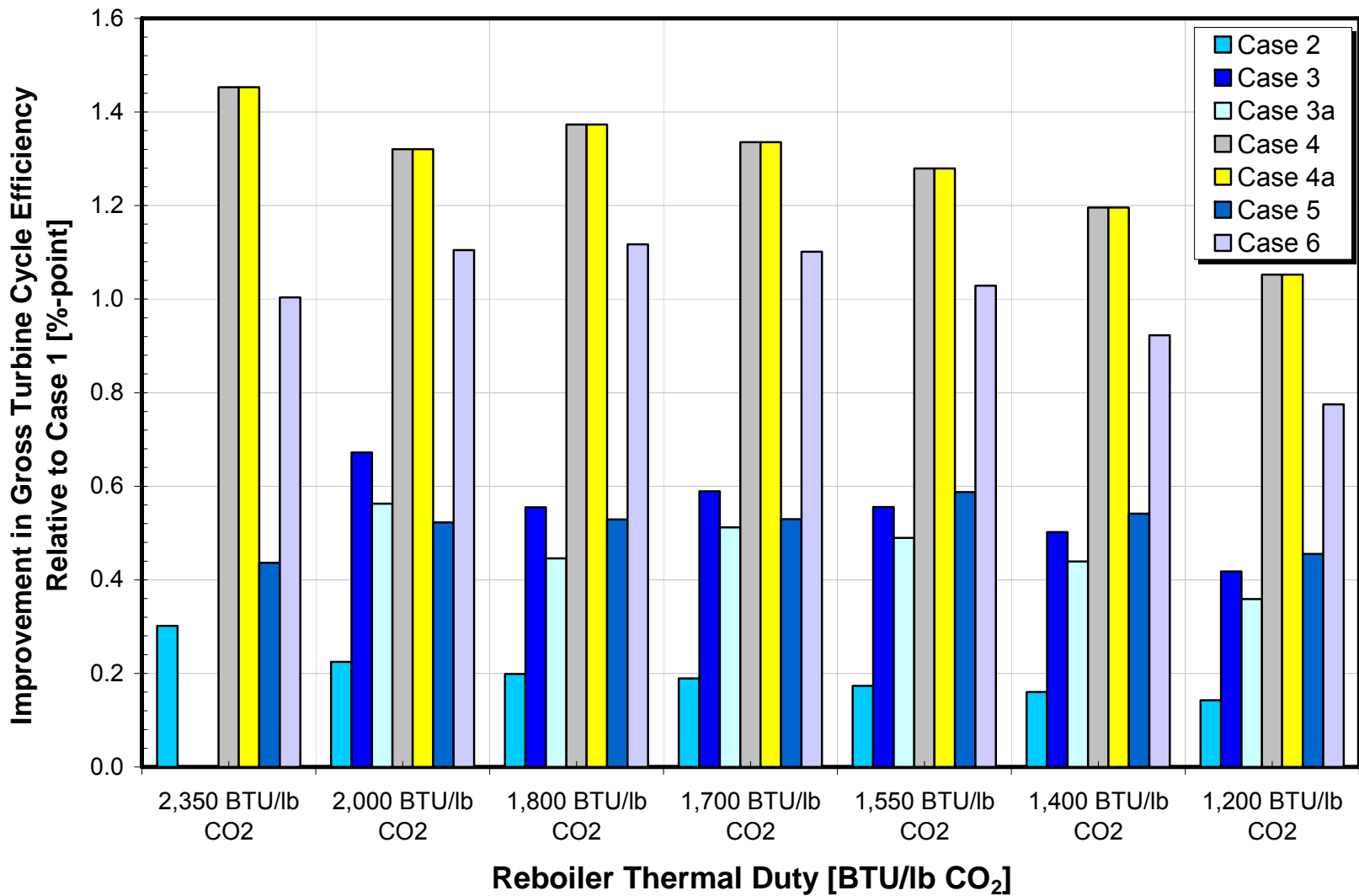

Summary of Results

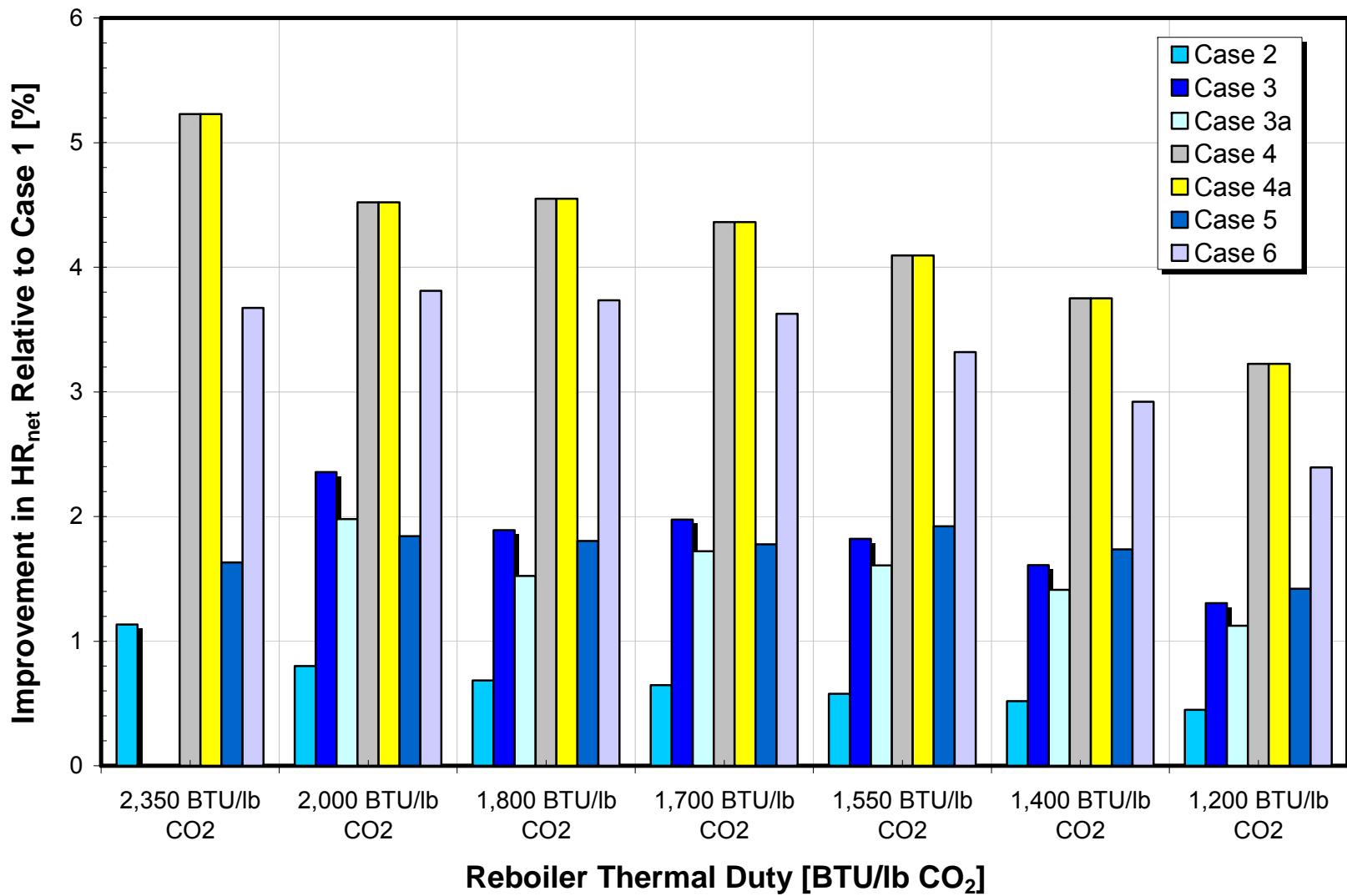

Summary of Results

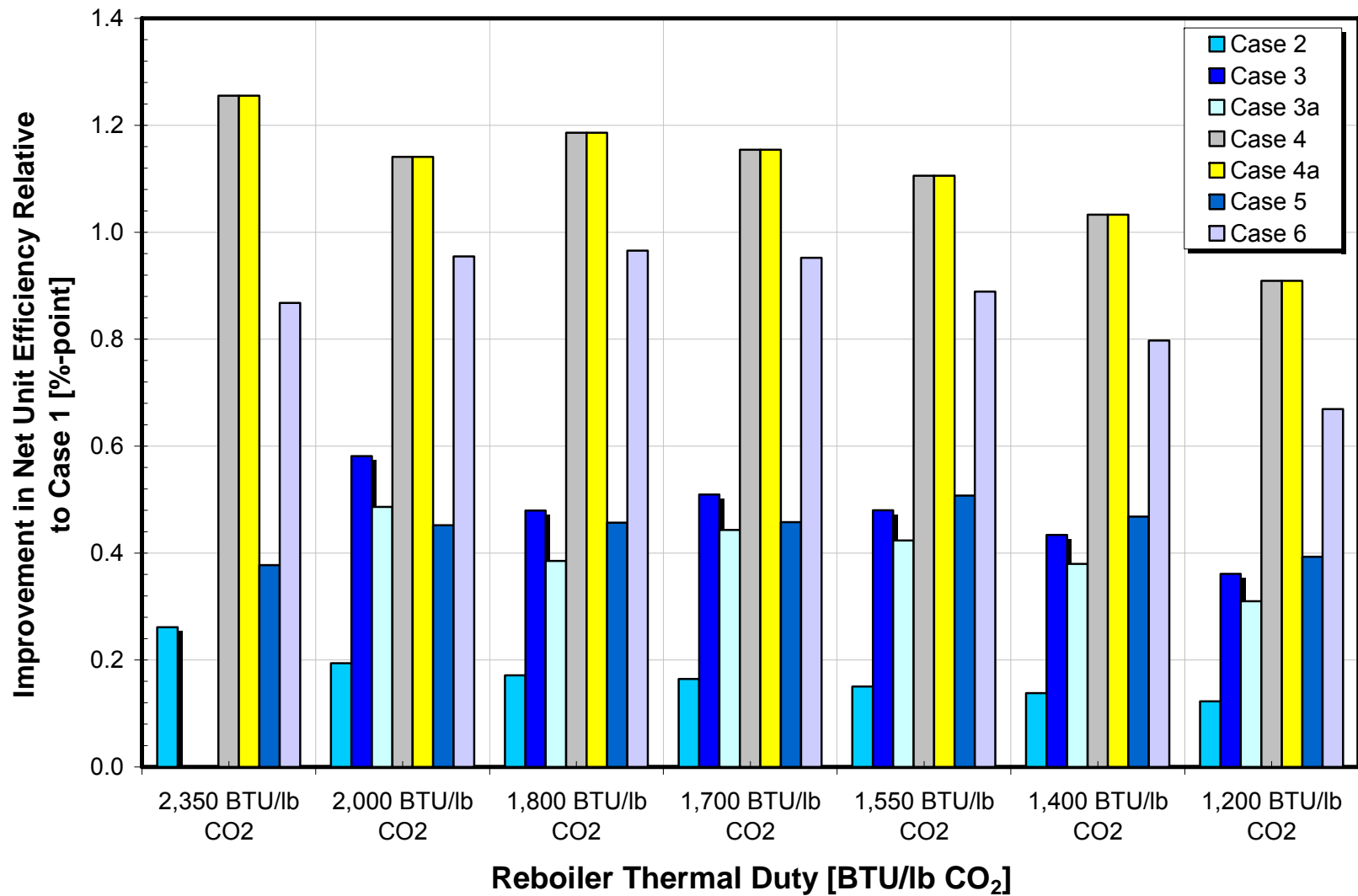

Integration of CO₂ Compression with Steam Turbine Cycle

Integration of CO₂ Compression with Steam Turbine Cycle

- Conventional CO₂ compression process involves multiple adiabatic compressors with inter-cooling to reach pressure required for delivery and underground storage.
- High-grade compression heat is used for FWH to improve performance of steam turbine cycle, and allow steam normally used for FWH to be used in reboiler.

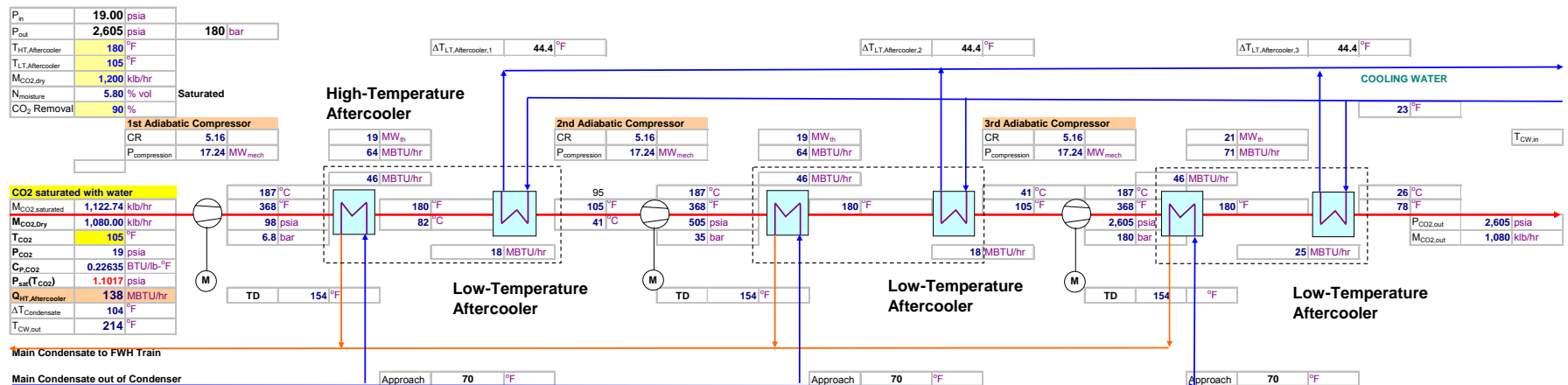

Integration of CO₂ Compression with Steam Turbine Cycle: Detail

P _{in}	19.00	psia	
P _{out}	2,605	psia	180 bar
T _{HT,Aftercooler}	180	°F	
T _{LT,Aftercooler}	105	°F	
M _{CO₂,dry}	1,200	klb/hr	
N _{moisture}	5.80	% vol	Saturated
CO ₂ Removal	90	%	
1st Adiabatic Compressor			
CR	5.16		
P _{compression}	17.24	MW _{mech}	

CO₂ saturated with water			
M _{CO₂,saturated}	1,122.74	klb/hr	
M _{CO₂,Dry}	1,080.00	klb/hr	
T _{CO₂}	105	°F	
P _{CO₂}	19	psia	
C _{p,CO₂}	0.22635	BTU/lb-°F	
P _{sat} (T _{CO₂})	1.1017	psia	

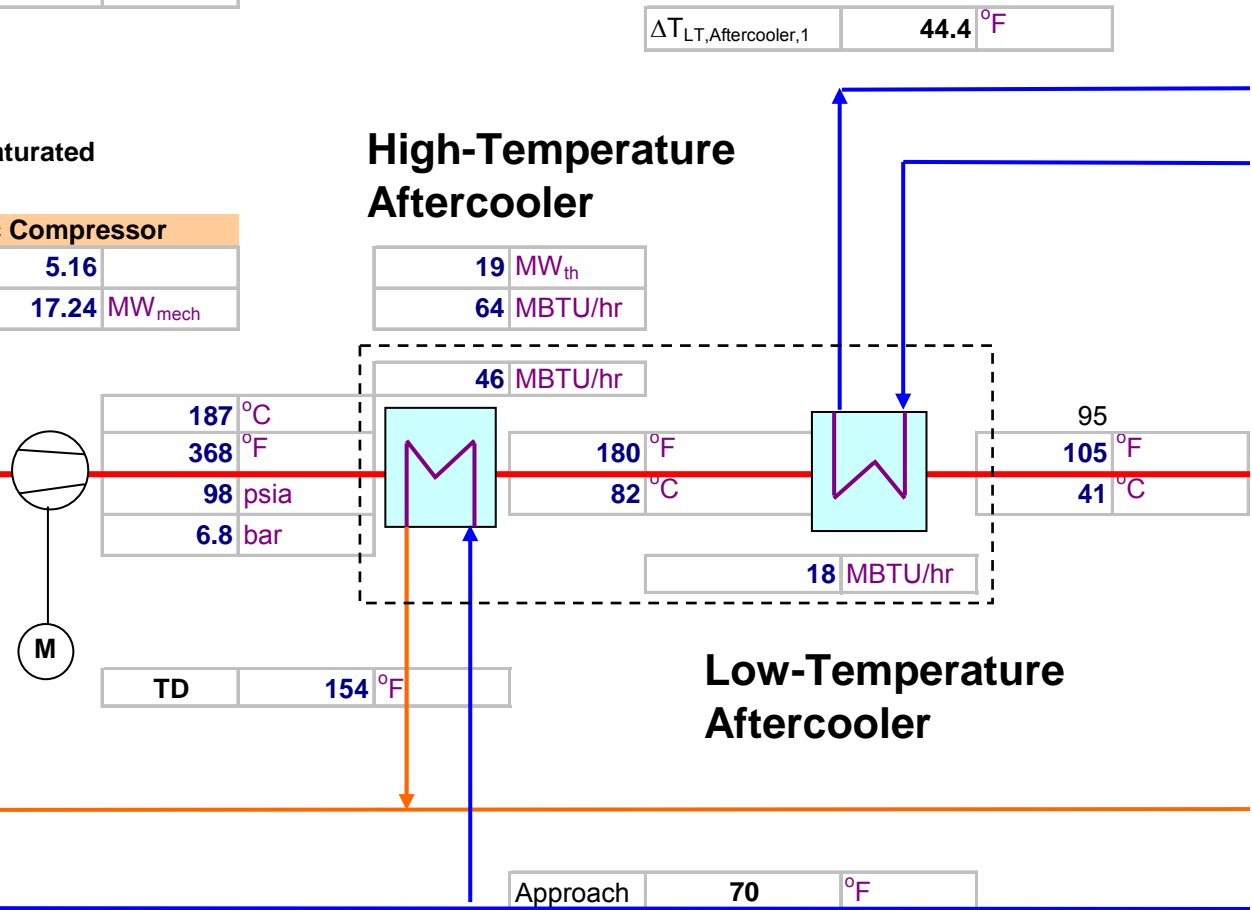

Main Condensate to FWH Train

Main Condensate out of Condenser

Integration of CO₂ Compression with Steam Turbine Cycle: Summary

CO ₂ Compression Layout	Note
Compression Train 1	Dry CO ₂
Compression Train 2	Dry CO ₂
Compression Train 3	CO ₂ Saturated by Moisture
Compression Train 4	CO ₂ Saturated by Moisture
Compression Train 5	CO ₂ Saturated by Moisture + Moisture Knockout
Compression Train 6	CO ₂ Saturated by Moisture + Moisture Knockout, Air Products-Doosan Babcock-Imperial College

CO ₂ Compression Layout	T _{in}	P _{in}	P _{out}		CR _{Overall}	M _{CO₂,dry}	M _{CO₂,wet}	Q _{HT Aftercooler}	Q _{LT Aftercooler}	P _{Compression}
	°F	psia	psia	bar						
Compression Train 1	105	14.7	1,595	110	108.5	1,080	1,080	128	55	55
Compression Train 2	105	14.7	2,605	180	177.2	1,080	1,080	149	55	62
Compression Train 3	105	19.0	2,605	180	137.1	1,080	1,123	138	62	52
Compression Train 4	105	19.0	2,200	152	115.8	1,080	1,123	130	62	50
Compression Train 5	105	19.0	2,015	139	106.1	1,080	1,123	136	61	60
Compression Train 6	105	19.0	1,595	110	83.9	1,080	1,123	143	67	63

CO ₂ Compression Layout	T _{in}	P _{in}	P _{out,1st Compressor}		CR ₁	T _{out,1st Compressor}		P _{out,2nd Compressor}		CR ₂	T _{out,2nd Compressor}		P _{out,3rd Compressor}		CR ₃	T _{out,3rd Compressor}	
	°F	psia	psia	bar		°F	°C	psia	bar		°F	°C	psia	bar		°F	°C
Compression Train 1	105	14.7	70	4.8	4.76	355	179	334	23	4.77	355	179	1,595	110	4.78	355	179
Compression Train 2	105	14.7	83	5.7	5.65	383	195	464	32	5.59	383	195	2,605	180	5.61	383	195
Compression Train 3	105	19.0	98	6.8	5.16	368	187	505	35	5.15	368	187	2,605	180	5.16	368	187
Compression Train 4	105	19.0	93	6.4	4.89	357	181	451	31	4.85	357	181	2,200	152	4.88	357	181
Compression Train 5	105	19.0	98	6.8	5.16	367	186	505	35	5.15	367	186	2,605	180	5.16	367	186
Compression Train 6	105	19.0	218	15	11.47	516	269	435	30	2.00	211	100	1,595	110	3.67	373	189

Partial CO₂ Scrubbing

Partial CO₂ Scrubbing

- ◉ *Involves modular design of CO₂ absorption-desorption process, where each module handles certain percentage (20 to 25%) of flue gas flow.*
- ◉ *Envisioned as a first step toward reducing CO₂ emissions from existing power plants.*
- ◉ *The first CO₂ scrubbing module to be retrofitted to an existing power plant will be designed to use as much recovered heat as possible, to minimize efficiency and capacity losses.*
- ◉ *Subsequent modules will be deployed as CO₂ scrubbing technology improves.*

Partial CO₂ Scrubbing

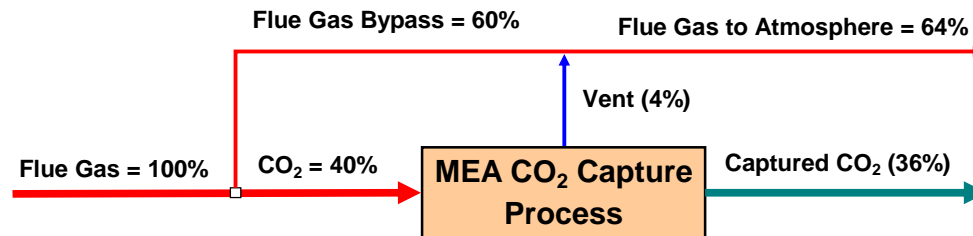
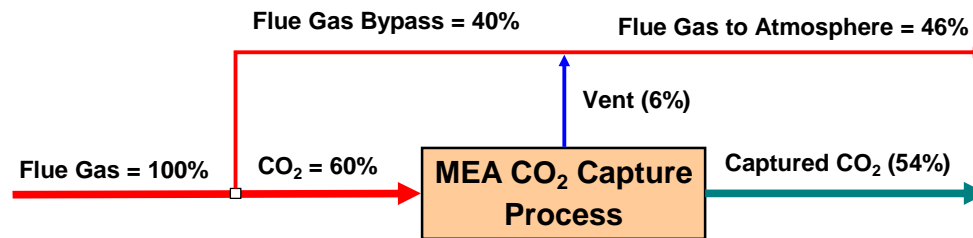
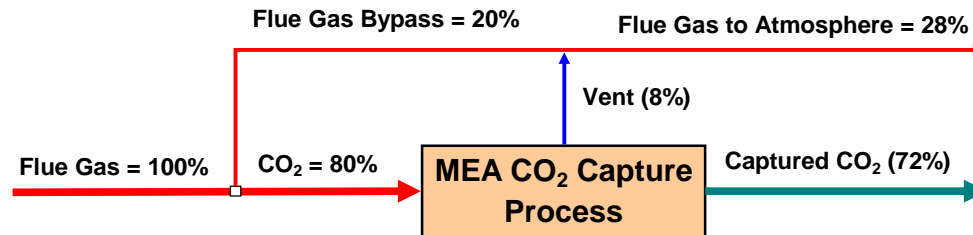
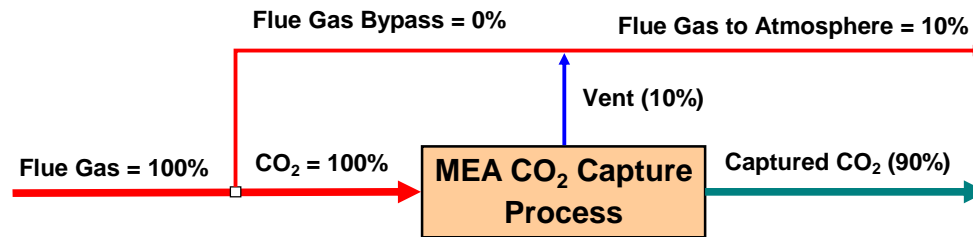

Partial CO₂ Scrubbing

- Partial CO₂ scrubbing – path to faster deployment of post-combustion CO₂ capture.
 - 35th International technical Conference on Clean Coal and Fuel Systems: Panel No. 7 “*Speeding up of CCS Deployment: High Efficiency Power Plants with Partial Capture of CO₂*”, Prof. Janos Beer (MIT), Jeff Philips (EPRI), Tom Stringer (Alstom Power), Prof. Lars Stromberg (Vattenfall R&D), Ligang Zheng (CANMET)
- **NYSERDA Project:** Heat integration of partial CO₂ scrubbing concept is in progress for analyzed cases.

Effect of Flue Gas Flow Rate on Stripper Energy

: ASPEN Simulation

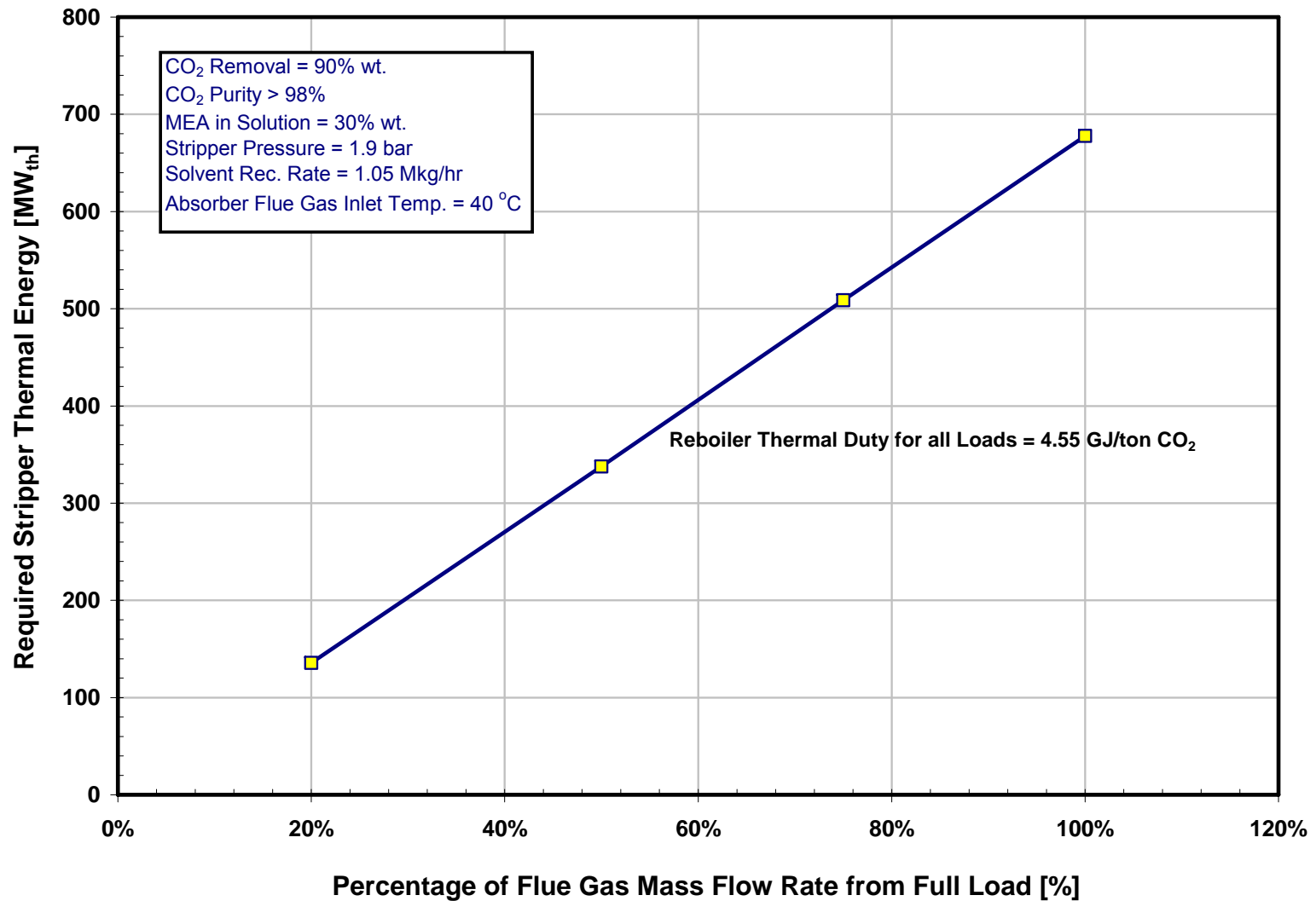

Results: Partial CO₂ Scrubbing

(Case 1, 2000 BTU/lb CO₂)

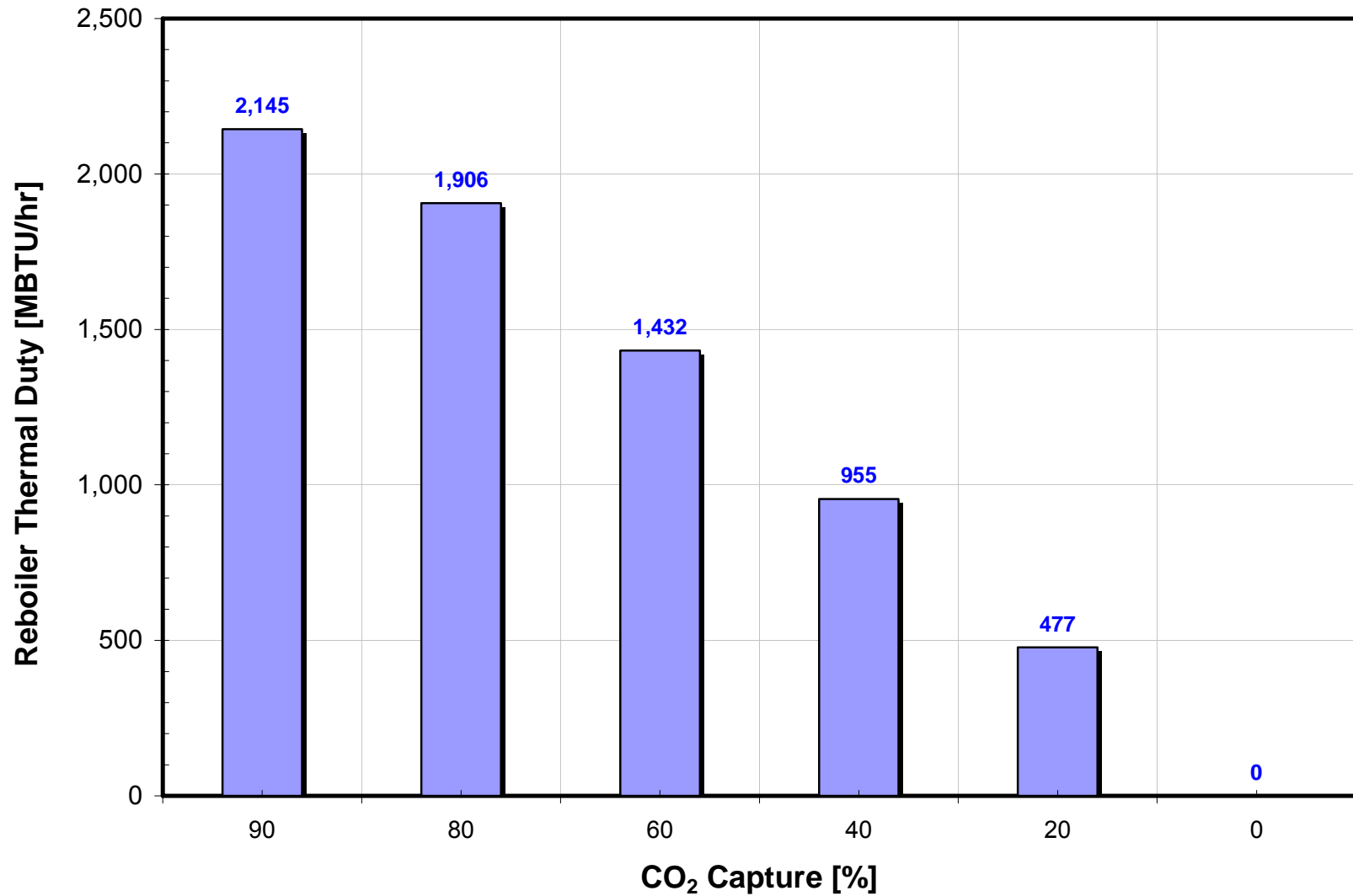

Results: Partial CO₂ Scrubbing

(Case 1, 2000 BTU/lb CO₂)

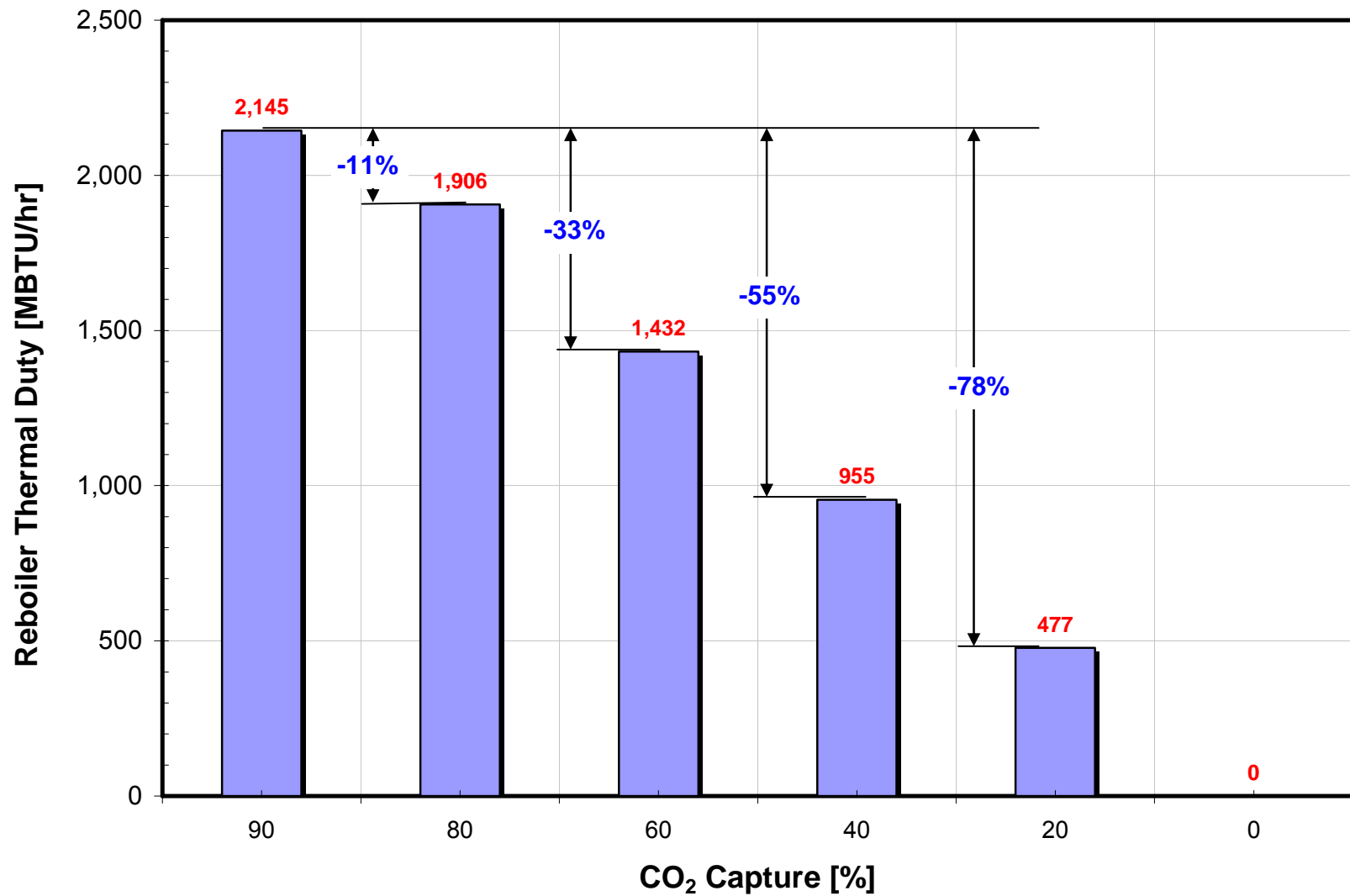

Results: Partial CO₂ Scrubbing

2,000 BTU/lb CO₂

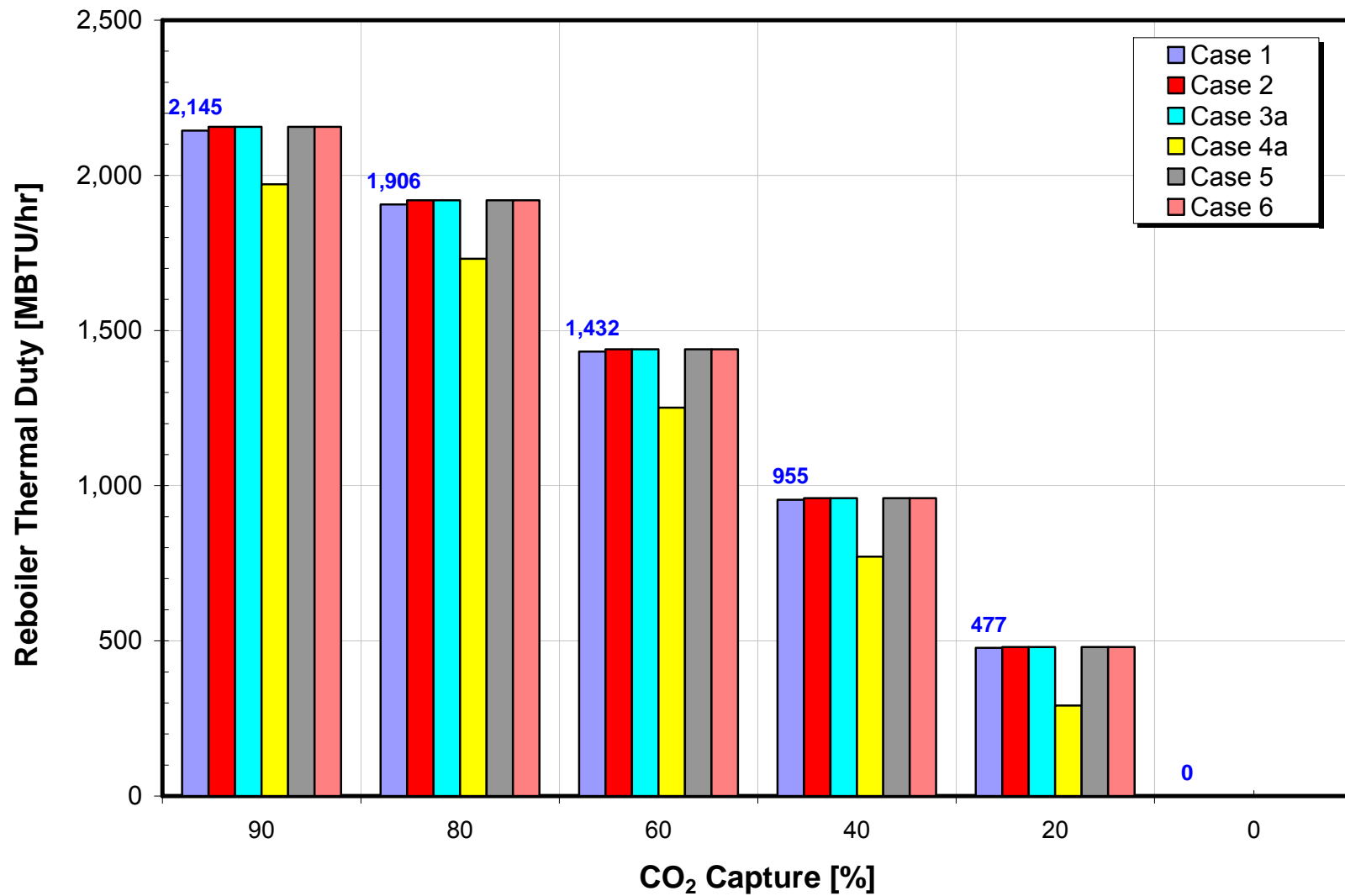

Results: Partial CO₂ Scrubbing

(Case 1, 2000 BTU/lb CO₂)

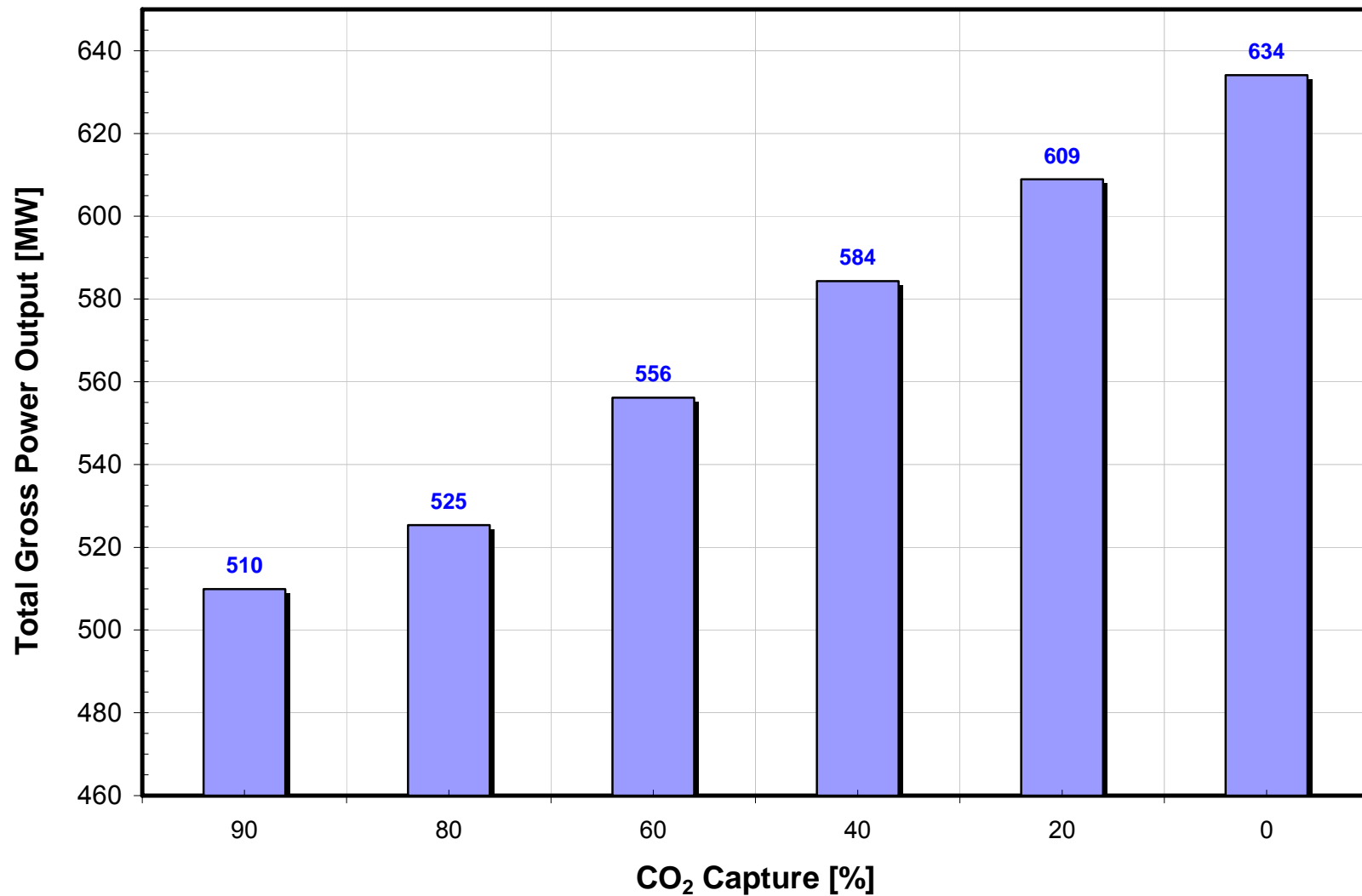

Results: Partial CO₂ Scrubbing

(Case 1, 2000 BTU/lb CO₂)

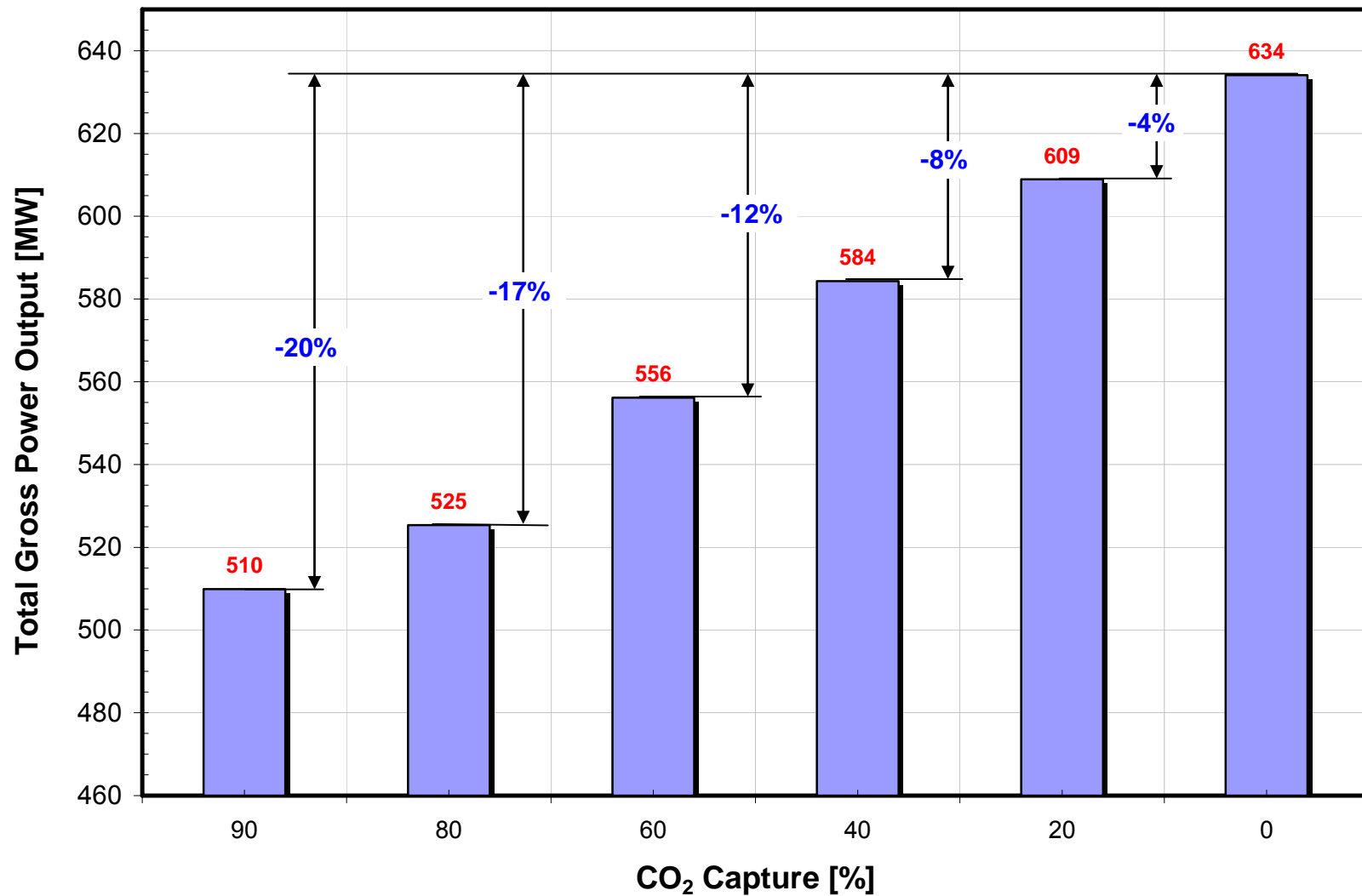

Results: Partial CO₂ Scrubbing

2,000 BTU/lb CO₂

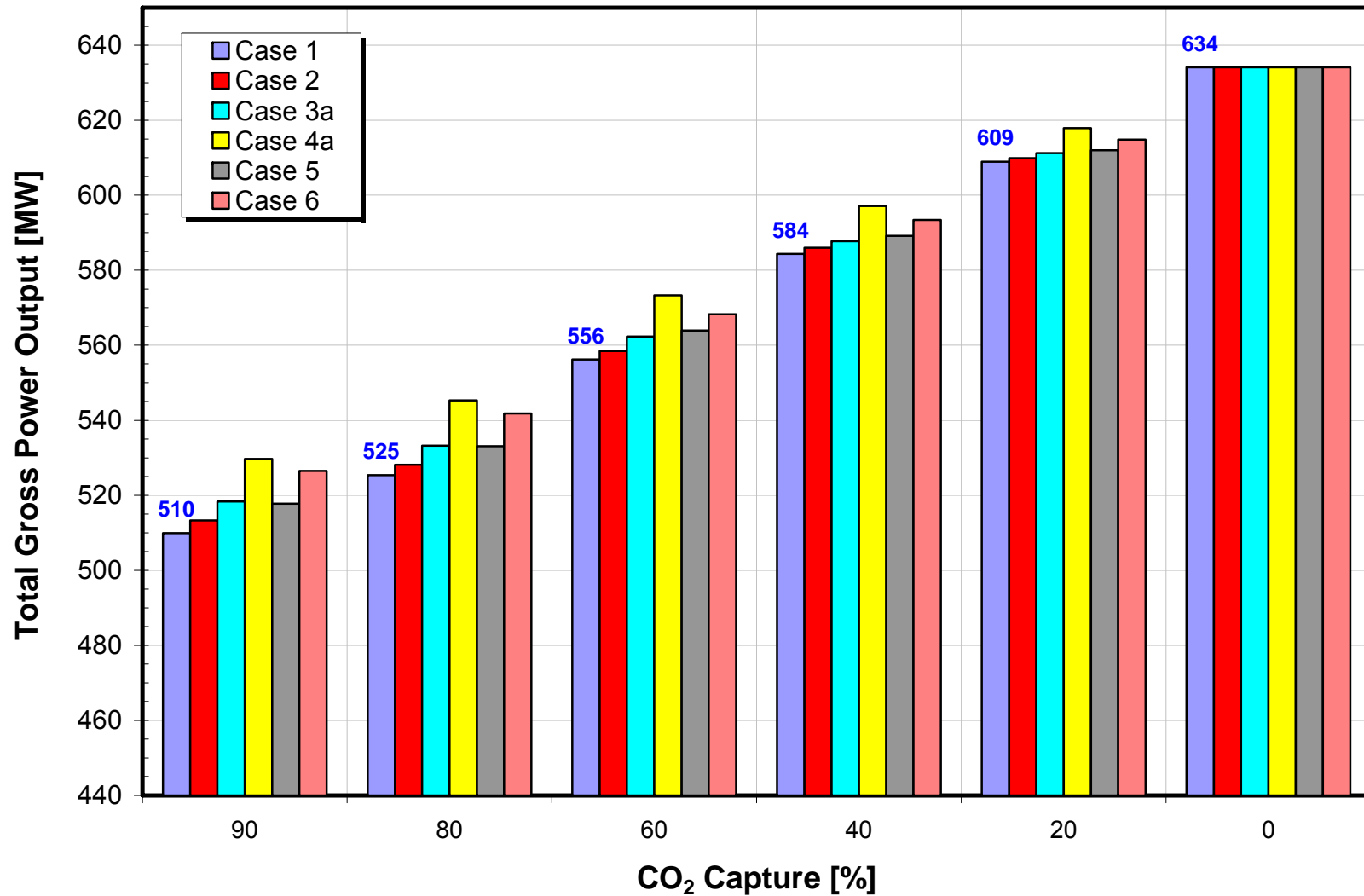

Results: Partial CO₂ Scrubbing

Case 1 (2,000 BTU/lb CO₂)

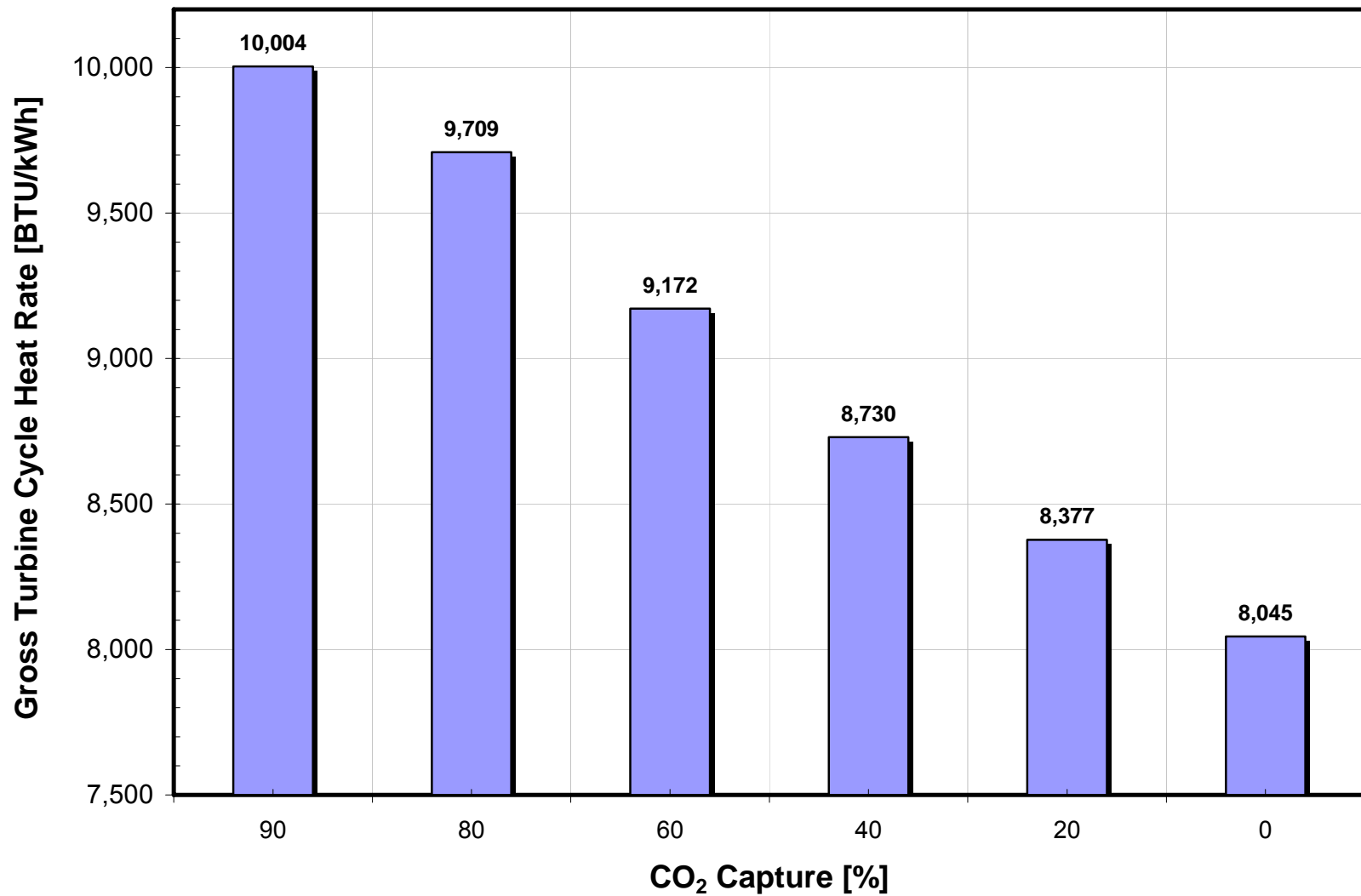

Results: Partial CO₂ Scrubbing

Case 1 (2,000 BTU/lb CO₂)

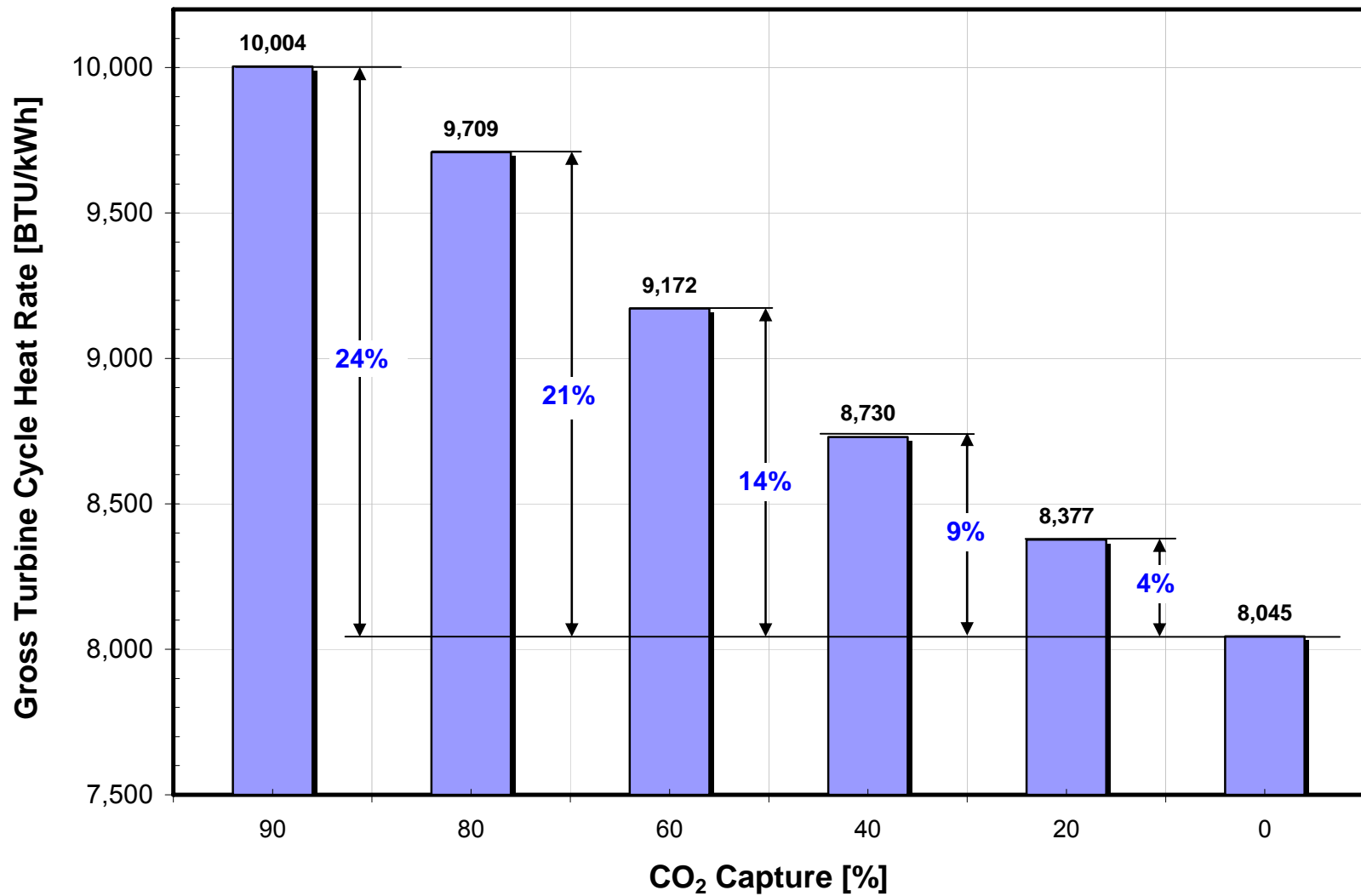

Results: Partial CO₂ Scrubbing

2,000 BTU/lb CO₂

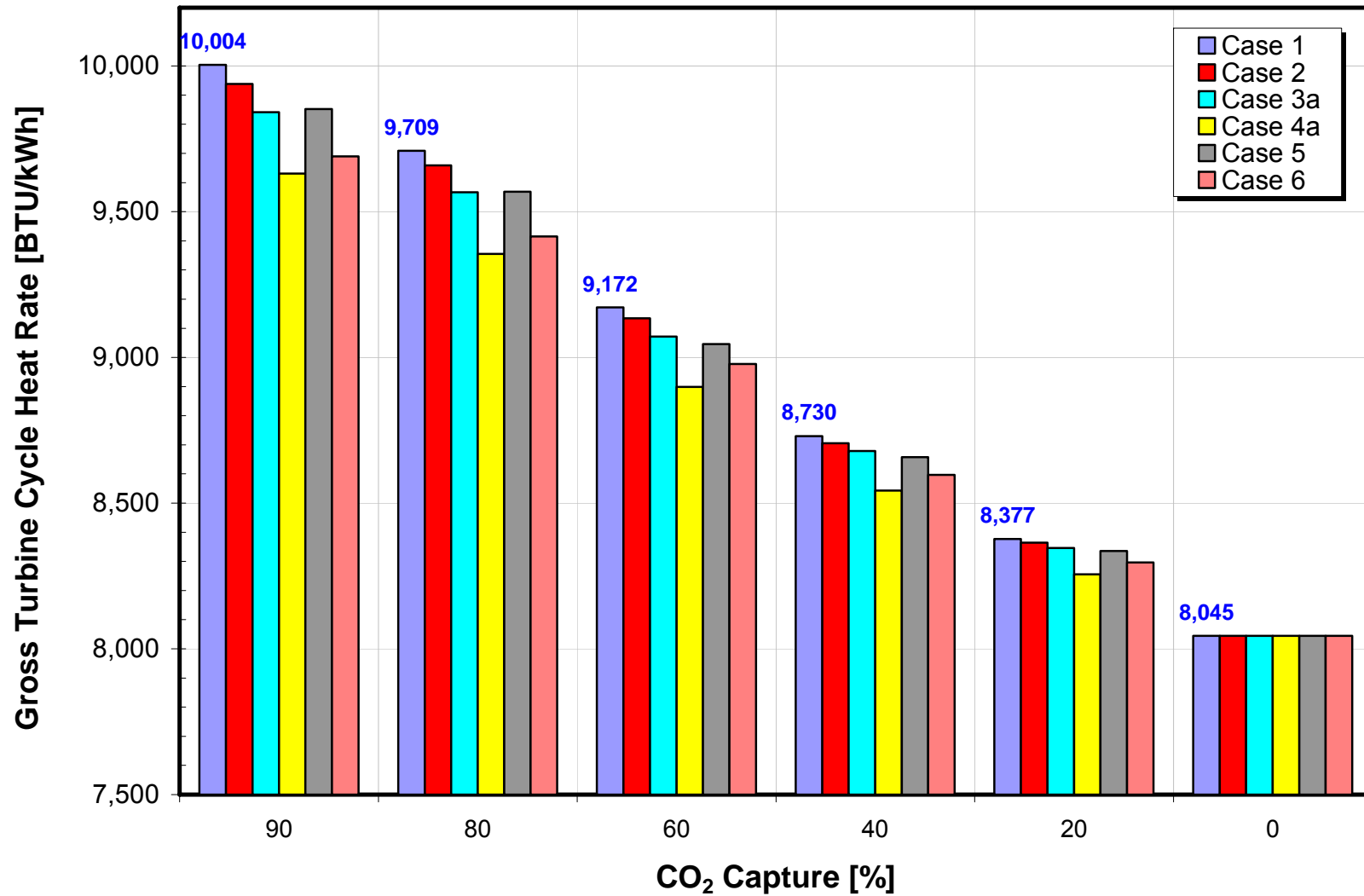

Conclusions

- *Heat recovered from flue gas and CO₂ compression heat can be used to partially offset efficiency and capacity losses due to post-combustion CO₂ capture.*
 - *Optimization of MEA CO₂ capture process can reduce reboiler thermal duty by 26%.*
 - *Performance of steam turbine cycle can be improved by up to 1.5% by using heat recovered from flue gas for low-pressure feed water heating.*
 - *Improvement in turbine cycle heat rate is significantly higher (more than 6%) if high-pressure feedwater heater steam extractions are eliminated.*
 - *Thermal integration of CO₂ stripper with plant waste heat sources can:*
 - *Reduce reboiler thermal duty by more than 8%.*
 - *Improve gross turbine cycle heat rate by 4.6% and cycle efficiency by 1.32%-points relative to conventional CO₂ scrubbing process.*
 - *Improve net unit heat rate by 4.5% and net unit efficiency by 1.14 %-points relative to conventional CO₂ scrubbing process.*
 - *Effect of partial CO₂ scrubbing on unit efficiency and capacity is linear.*
 - *Development of advanced CO₂ sorbents is critical to reducing performance and capacity penalty due to CO₂ capture.*



Questions ?