



Department of Materials Science and
Engineering

UNDERGRADUATE HANDBOOK



P. C. Rossin College of
Engineering and Applied Science

Table of Contents

Introduction	1
A. Academics	
1. The undergraduate program in Materials Science and Engineering	
a. Required courses for the B.S. degree	3
b. Electives.....	7
i. Engineering Science Electives	8
ii. Approved Electives.....	10
2. Minors	
a. Minors for students majoring in Materials.....	13
b. Minor in Nanotechnology	13
c. Minor in Materials (for students in other disciplines)	15
d. General rules for Minors.....	16
e. Appendices for Minors	17
3. The Materials program for students in the IBE (Integrated Business and Engineering) program.....	22
4. How an IBE student can get an accredited degree in Materials Science and Engineering.	25
5. Integrated Degree – Engineering, Arts & Sciences (IDEAS).....	26
6. Prerequisites and the waiving of prerequisites.....	28
7. Undergraduate Student Overload Policy.....	29
B. Other	
1. Department Awards	32
2. The Student Materials Society	33
3. The Lehigh Microscopy School (in June each year)	34
C. Some words of advice from the faculty “in loco parentis”	
1. Choosing HSS courses.....	36
2. Choosing Electives	36
3. Troubles.....	37

Introduction

The aim of this handbook is to provide students of the Department of Materials Science and Engineering with a source of information specific to the Department. We hope that it will help you during your time with us.

Lehigh University as a whole has two publications that represent the primary authorities for matters pertaining to students. These are:

1. The Lehigh University Course Catalog –
<http://www3.lehigh.edu/academics/catalog/default.asp>
2. The Lehigh University Student Handbook –
<http://www.lehigh.edu/~indost/dos/hbook.html>

This Materials Science and Engineering Handbook does not replace nor supersede these Lehigh University authorities for students. Where this handbook is in disagreement with them, they should be taken as correct.

You may have a paper copy of both the Course Catalog and the Student Handbook. However, both of these documents have been moved onto the Lehigh website. You should get used to consulting them there. Note that, generally speaking, the academic rules that apply are those that were in the Catalog when you entered Lehigh. If rules change while you are in a program, you may have a choice of going by the old rules (the ones when you started) or going by the new rules. Rules governing non-academic aspects of student life generally come into effect immediately and there will be no option to continue by old rules.

A. Academics

B.S. in Materials Science and Engineering

The program for the **BS in Materials Science and Engineering** consists of the common first year for engineering students followed by the program of courses listed for each undergraduate year below.

Class of 2010

Class of 2011

CURRICULUM		CURRICULUM	
<p>Year 1 <u>29 credits total</u></p> <p>Fall <u>17 credits</u></p> <p>Soph 4 Math 23 Analytic Geom. & Calculus III 5 Phys 21,22 Physics II and Lab 4 Eco 1 Economics 1 MAT 10 Materials Laboratory 3 MAT 33 Engr. Materials & Processes</p> <p>Spring <u>18 credits</u></p> <p>Soph 3 Math 205 Linear Methods 3 Mech 195 Engineering Mechanics 3 MAT 203 Structure & Characterization 3 MAT 205 Thermo & Phase Diagrams 3 MAT 20 Computational Methods 3 HSS 1</p> <p>Fall <u>18 credits</u></p> <p>Junior 3 MAT 201 Physical Properties of Materials 3 MAT 218 Mechanical Behavior 3 MAT 216 Diffusion & Phase Trans. 2 MAT 101 Professional Development 3 Free Elective 1 4 HSS 2</p> <p>Spring <u>18 credits</u></p> <p>Junior 3 ENGR 211 IPD #1 3 MAT 204 Polymers 3 MAT 206 Metals 3 MAT 214 Ceramics 3 Free Elective 2 3 HSS 3</p> <p>Fall <u>18 credits</u></p> <p>Senior 2 ENGR 212 IPD #2 3 MAT 302 Electronic Properties of Matls 3 Eng. Sci. Elect. 1 3 Eng. Sci. Elect. 2 3 Free Elective 3 4 HSS 4</p> <p>Spring <u>16 credits</u></p> <p>Senior 3 MAT 338 Matls Selection & Failure Anal. 3 ChemE 60 Unit Operations Survey 3 ECE 83 Intro to Electrical Engineering 1 ECE 162 Electrical Laboratory 3 Approved Elective 3 Free Elective 4</p>	<p>Year 1 <u>29 credits total</u></p> <p>Fall <u>17 credits</u></p> <p>Soph 4 Math 23 Analytical Geom. & Calculus III 5 Phys 21,22 Physics II and Lab 4 Eco 1 Economics 1 MAT 10 Materials Laboratory 3 MAT 33 Engr. Materials & Processes</p> <p>Spring <u>18 credits</u></p> <p>Soph 3 Math 205 Linear Methods 3 Mech 3 Engineering Mechanics 3 MAT 203 Structure & Characterization 3 MAT 205 Thermo & Phase Diagrams 3 MAT 20 Computational Methods 3 HSS 1</p> <p>Fall <u>18 credits</u></p> <p>Junior 3 MAT 201 Physical Properties of Materials 3 MAT 218 Mechanical Behavior 3 MAT 216 Diffusion & Phase Trans. 2 MAT 201 Professional Development 3 Free Elective 1 4 HSS 2</p> <p>Spring <u>18 credits</u></p> <p>Junior 3 ENGR 211 IPD #1 3 MAT 204 Polymers\ 3 MAT 206 Metals 3 MAT 214 Ceramics 3 Free Elective 2 3 HSS 3</p> <p>Fall <u>15 credits</u></p> <p>Senior 2 ENGR 212 IPD #2 3 MAT 302 Electronic Properties of Matls. 3 Eng. Sci. Elective 1 3 Eng. Sci. Elective 2 4 HSS 4</p> <p>Spring <u>16 credits</u></p> <p>Senior 3 MAT 338 Matls. Select. & Failure Anal. 3 ChemE 60 Unit Operations Survey 3 ECE 83 Intro to Electrical Engineering 1 ECE 162 Electrical Laboratory 3 Approved Elective 3 Free Elective 3</p>		
TOTAL: 134 credits	TOTAL: 131 credits		

Class of 2012

CURRICULUM	
Year 1	<u>29 credits total</u>
Fall Soph	<u>18 credits</u> 4 Math 23 Analytical Geom. & Calculus III 5 Phys 21,22 Physics II and Lab 4 Eco 1 Economics 2 MAT 10 Materials Laboratory 3 MAT 33 Engr. Materials & Processes
Spring Soph	<u>18 credits</u> 3 Math 205 Linear Methods 3 Mech 3 Engineering Mechanics 3 MAT 203 Structure & Characterization 3 MAT 205 Thermo & Phase Diagrams 3 MAT 20 Computational Methods 3 HSS 1
Fall Junior	<u>18 credits</u> 3 MAT 201 Physical Properties of Materials 3 MAT 218 Mechanical Behavior 3 MAT 216 Diffusion & Phase Trans. 2 MAT 101 Professional Development 3 Free Elective 1 4 HSS 2
Spring Junior	<u>18 credits</u> 3 ENGR 211 IPD #1 3 MAT 204 Polymers 3 MAT 206 Metals 3 MAT 214 Ceramics 3 Free Elective 2 3 HSS 3
Fall Senior	<u>15 credits</u> 2 ENGR 212 IPD #2 3 MAT 302 Electronic Properties of Matls 3 Eng. Sci. Elective 1 3 Eng. Sci. Elective 2 4 HSS 4
Spring Senior	<u>16 credits</u> 3 MAT 338 Matls Select. & Failure Anal. 3 ChemE 60 Unit Operations Survey 3 ECE 83 Intro to Electrical Engineering 1 ECE 162 Electrical Laboratory 3 Approved Elective 3 Free Elective 3

TOTAL: 132 credits

B.S. in Materials Science and Engineering

The list of courses required for the BS in Materials Science and Engineering is given on the previous pages. On the next page is a chart that shows, in diagrammatic form, the structure of the program.

Each horizontal row of courses on the chart represents a semester of the standard program. For example, the third row down on the chart (MATH 23, PHYS 21, PHYS 22, MAT 33, MAT 10, and ECO 1) gives the courses that most students will take in the Fall of the sophomore year. Students with AP credit may be ahead of this standard program and others may be behind.

On the chart, lines represent prerequisite relationships. Where there is a line with a single arrowhead, the course at the start of the line must be completed (with a C- or higher) before the course at the arrowhead can be taken. Where the line ends with a double arrowhead, the prerequisite course may be taken concurrently with the course for which it is a prerequisite. These prerequisite relationships given on the chart are for guidance only. The catalog is the official source of information regarding prerequisites.

Many of the elective courses also have prerequisites. These are not shown on the chart.

A student must obtain a 2.0 average in the “major courses” to graduate in Engineering. “Major courses” for Materials Science and Engineering consist of all MAT courses taken to satisfy the major.

Important Note:

Most of the materials science courses are given only once a year. That is to say that they are given either only in the Fall or only in the Spring. This means that if you get out of step with the standard sequence, you may have trouble completing the program on time, because of the very tight linking of prerequisites.

**Undergraduate Program in Materials Science and Engineering
2009**

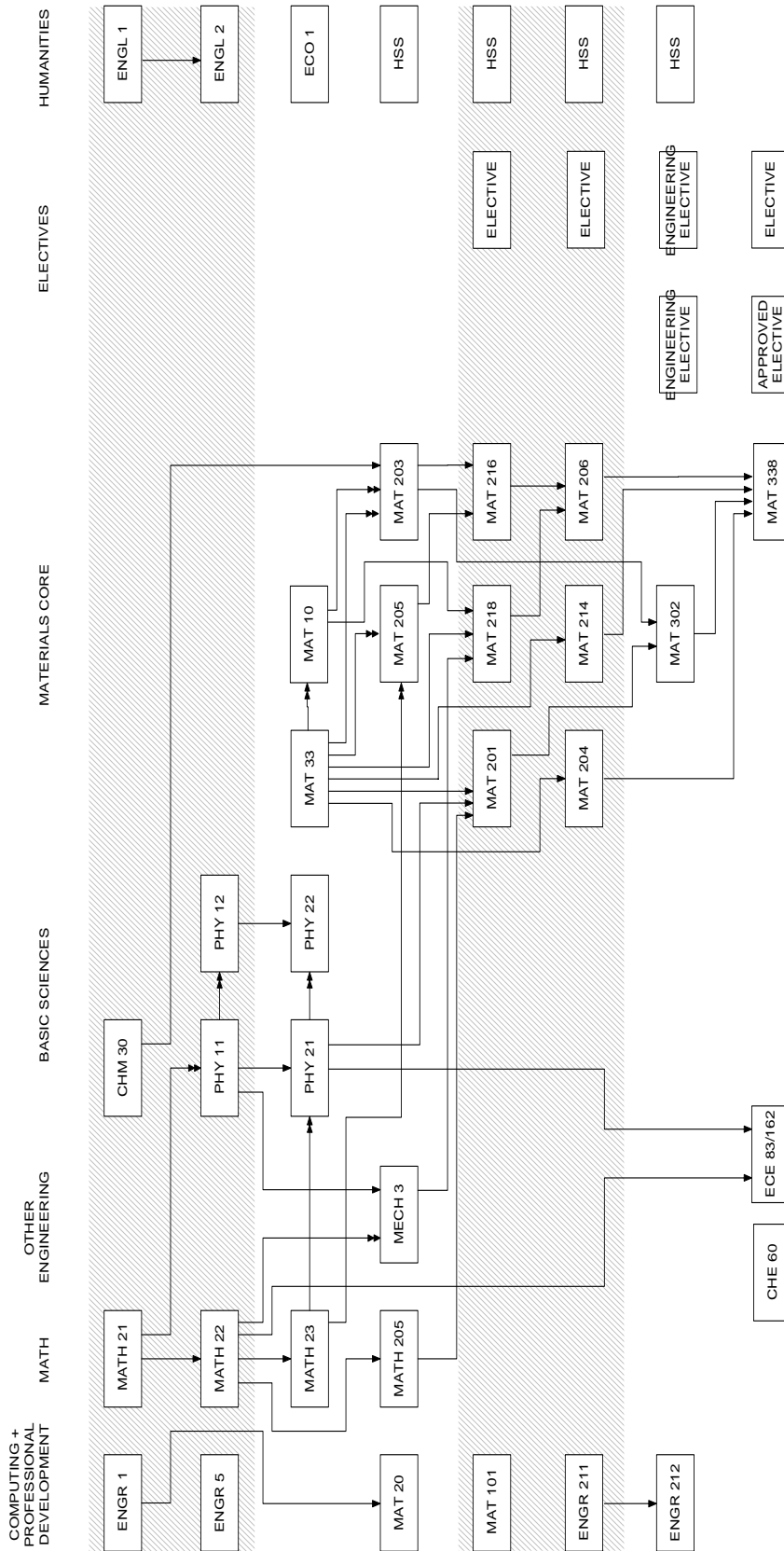

Electives

The program in Materials Science and Engineering includes a number of elective courses. The aim of including such courses is to allow you to tailor the program to reflect your interests. There are several classes of electives. Details are given below.

Engineering Science Electives (two 3-credit courses)

These two courses are closely related to the core of the materials program. The idea is that, although these are part of the materials program, they give you the opportunity to develop specialization in an area of interest to you. For example, you may want to learn more about polymer materials than the required courses give, then you would take engineering science elective courses in this area. There is a list of courses from which the engineering science electives may be chosen. The list is given on following pages.

Approved Elective (one 3-credit course)

This is a course that contributes to your materials education but in a less direct way than the required courses or the engineering science elective courses. It is a way of providing increased breadth in your technical education. A list of courses from which you may choose is given on the following pages.

Free electives (three 3-credit courses)

To satisfy this requirement, you may take any three courses (with a minimum of three credits each) that Lehigh offers.

HSS

In addition to the above courses, students in Materials Science and Engineering (like all engineering students at Lehigh) must take a set of courses in the humanities and social sciences. This is known informally as the HSS requirement. The rules governing the HSS requirement are given in the catalog (starting on page 44 of the 2009-2010 catalog). You should study these rules and make sure to plan your HSS courses to meet them.

A course which is eligible to count as a social sciences course for HSS has **(SS)** at the end of the corresponding entry in the catalog. A course which is eligible to count as a humanities course for HSS has **(HU)** at the end of the corresponding entry in the catalog. A course that does not have such an entry can not be counted towards HSS.

The only exception to this rule is that Law 101 is accepted as meeting HSS requirements.

Engineering Science Electives

MAT 240	Research Techniques
MAT 291	Undergraduate Research
MAT 309	Composite Materials
MAT 312	(ChE, Chem) Fundamentals of Corrosion
MAT 314	Metal Forming Processes
MAT 315	Physical Properties of Structural and Electronic Ceramics
MAT 317	Imperfections in Crystals
MAT 320	Analytical Methods in Materials Science
MAT 324	Intro to Organic Biomaterials
MAT 325	Inorganic Biomaterials
MAT 327	Industrial Project
MAT 329	Industrial Project
MAT 333	(EES 337, Chm 337) Crystallography and Diffraction
MAT 334	(EES 338, ChE 334) Electron Microscopy and Microanalysis
MAT 335	(ChE 335) Principles of Semiconductor Materials Processing
MAT 339	Light Metals
MAT 342	Inorganic Glasses
MAT 344	(IE 344) Metal Machining Analysis (3) spring
MAT 345	Powder Metallurgy
MAT 346	Welding
MAT 348	Materials Science for Electronic Applications
MAT 355	Materials for Nanotechnology
MAT 356	Strategies for Nanocharacterization
MAT 359	Thin Films
MAT 393	(ChE 393, Chm 393) Physical Polymer Science
MAT 396	(Chem 396) Chemistry of Nonmetallic Solids
ChE 044	Fluid Mechanics
ChE 210	Chemical Engineering Thermodynamics
ChE 312	(Chm 312, Mat 312) Fundamentals of Corrosion
ChE 394	(Chm 394) Organic Polymer Science I
Chm 051	Organic Chemistry I
Chm 052	Organic Chemistry II
CEE 121	Mechanics of Fluids
CEE 159	Structural Analysis
CEE 259	Structural Analysis II
CSE 017	Structured Programming and Data Structures
ECE 108	Signals and Systems
ECE 123	Electronic Circuits
ECE 125	Circuits and Systems
ECE 126	Fundamentals of Semiconductor Devices
ECE 202	Introduction to Electromagnetics
ECE 203	Introduction to Electromagnetic Waves
ECE 212	Control Theory

Engineering Science Electives

(Continued)

ECE 337	Micro & Nano Fabrication
ECE 342	Communication Theory
ECE 343	Digital Signal Processing
ECE 351	Microelectronics Technology
IE 121	Applied Engineering Statistics
IE 168	Production Analysis
IE 220	Introduction to Operations Research
IE 226	Engineering Economy and Decision Analysis
IE 316	Advanced Operations Research Techniques
IE 332	Product Quality
ME 010	Graphics for Engineering Design
ME 104	Thermodynamics I
ME 231	Fluid Mechanics
ME 242	Mechanical Engineering Systems
ME 321	Introduction to Heat Transfer
ME 331	Advanced Fluid Mechanics
ME 343	Control Systems
ME 348	Computer-Aided Design
Mech 012	Strength of Materials
Mech 102	Dynamics
Mech 103	Principles of Mechanics
Mech 302	Advanced Dynamics
Mech 305	Advanced Mechanics of Materials
Mech 307	Mechanics of Continua
Mech 313	Fracture Mechanics

Approved Electives

MAT 107	Special Topics in Materials
MAT 240	Research Techniques
MAT 291	Undergraduate Research
MAT 309	Composite Materials
MAT 315	Physical Properties of Structural and Electronic Ceramics
MAT 319	Current Topics in Materials Science
MAT 320	Analytical Methods in Materials Science
MAT 324	Intro to Organic Biomaterials
MAT 325	Inorganic Biomaterials
MAT 327	Industrial Project
MAT 329	Industrial Project
MAT 342	Inorganic Glasses
MAT 355	Materials for Nanotechnology
MAT 356	Strategies for Nanocharacterization
MAT 359	Thin Films
MAT 396	Chemistry of Nonmetallic Solids
ACCT 108	Fundamentals of Accounting
ACCT 151	Introduction to Financial Accounting
ACCT 152	Introduction to Managerial Accounting
Bus 127	Information Analysis and Financial Decision Making
ChE 031	Material and Energy Balances of Chemical Processes
ChE 044	Fluid Mechanics
ChE 151	Introduction to Heat Transfer
ChE 201	Methods of Analysis in Chemical Engineering
ChE 386	Process Control
ChE 394	(Chm 394) Organic Polymer Science I
Chm 031	Chemical Equilibria in Aqueous Systems
Chm 051	Organic Chemistry
Chm 388	Polymer Synthesis and Characterization Laboratory
Chm 392	Introduction to Polymer Science
Chm 394	Organic Polymer Science
CEE 121	Mechanics of Fluids
CSC 017	Structured Programming and Data Structures
ECE 126	Fundamentals of Semiconductor Devices
ECE 202	Introduction to Electromagnetics
ECE 203	Introduction to Electromagnetic Waves
ECE 337	Micro & Nano Fabrication
ECE 351	Microelectronics Technology
EES 316	Hydrogeology
EES 320	Flood Hydrology and Hydraulics
EES 323	Environmental Groundwater Hydrology

Approved Electives

(Continued)

EES 327	Surface Water Quality Modeling
EES 334	Petrology of the Crust and Mantle
EES 341	Field Geology
EES 357	Paleoecology and Landscape History
EES 379	Environmental Case Studies
EES 393	Supervised Research in Earth and Environmental Sciences
IE 121	Applied Engineering Statistics
IE 131	Work Systems and Facilities Planning
IE 168	Production Analysis
IE 224	Information Systems Analysis and Design
IE 319	Material Handling and Facilities Planning
IE 324	Industrial Automation and Robotics
IE 332	Product Quality
IE 334	Organizational Planning and Control
IE 340	Production Engineering
IE 344	Metal Machining Analysis
JOUR 311	Science and Technical Writing
JOUR 312	Advanced Science Writing
LAW 101	Introduction to Law
LAW 201	Legal Environment of Business
LAW 202	Business Law
Math 201	Problem Solving
Math 202	Actuarial Exam
Math 207	Introduction to Biomedical Engineering and Mathematical Physiology
Math 208	Complex Variables
Math 230	Numerical Methods
Math 231	Probability and Statistics
Math 234	Fractal Geometry
Math 242	Linear Algebra
Math 243	Algebra
Math 251	Combinatorics
Math 261	Discrete Structures
Math 301	Principles of Analysis I
Math 302	Principles of Analysis II
Math 303	Mathematical Logic
Math 304	Axiomatic Set Theory
Math 307	General topology
Math 309	Theory of Probability
Math 310	Probability and Its Applications
Math 312	Computational Statistics
Math 316	Complex Analysis
Math 320	Ordinary Differential Equations
Math 322	Methods of Applied Analysis

Approved Electives

(Continued)

Math 323	Methods of Applied Analysis II
Math 327	Groups and Rings
Math 329	Recursive Functions and the Theory of Computation
Math 334	Mathematical Statistics
Math 338	Regression Analysis
Math 340	Design and Analysis of Algorithms
Math 341	Mathematical Models and Their Formulation
Math 342	Number Theory
Math 350	Special Topics
Math 371	Readings
Math 374	Statistical Project
Math 391	Senior Honors Thesis
Mech 012	Strength of Materials
Mech 305	Advanced Mechanics of Materials
Mech 313	Fracture Mechanics
Phil 128	Philosophy of Science
Phy 201	Modern Astrophysics I
Phy 202	Modern Astrophysics II
Phy 212	Electricity and Magnetism
Phy 213	Electricity and Magnetism
Phy 215	Classical Mechanics
Phy 262	Advanced Physics Laboratory
Phy 273	Research
Phy 281	Basic Physics I
Phy 282	Basic Physics II
Phy 332	High-Energy Astrophysics
Phy 340	Thermal Physics
Phy 342	Relativity and Cosmology
Phy 348	Plasma Physics
Phy 352	Modern Optics
Phy 355	Lasers and Non-linear Optics
Phy 362	Atomic and Molecular Structure
Phy 363	Physics of Solids
Phy 365	Physics of Fluids
Phy 369	Quantum Mechanics
Phy 372	Special Topics in Physics
Phy 380	Introduction to Computational Physics
STS 198	Nanotechnology in Society

Minors in the Department of Materials Science and Engineering

The Department of Materials Science and Engineering offers minors to students majoring in other subjects and supports minors for students majoring in the materials program. The Department is enthusiastic in its support of students who wish to broaden their education by taking a minor.

a. Minors for Students Majoring in Materials

Students majoring in Materials Science and Engineering are encouraged to take a minor in another field.

In four cases, where the match between the major and the minor is particularly good, the Department has made specific arrangements with the corresponding departments to establish minors. These are for minors in Chemical Engineering, in Industrial and Systems Engineering, Mechanical Engineering, and in Polymer Science and Engineering. Details are given below, see appendices 2, 3, 4 and 5.

Many other minors are possible and encouraged, including minors in other engineering departments (Computer Science, Environmental Engineering) as well as in other colleges. There are about sixty minors available in the College of Arts and Sciences, reflecting a very broad range of interests. There is a minor in Education. A minor in Business has recently been started. In these cases there is no specific arrangement made for Materials majors. The normal procedure is for the student to make arrangements directly with the department in question. It would be helpful to deposit a copy of the paperwork in the Materials office.

A student who is contemplating the possibility of taking a minor should start by talking to his or her advisor but should also talk to the person responsible for the minor program in the department hosting the minor (normally the associate chair but the departmental secretary will be able to say who it is).

b. Minor in Nanotechnology

Materials for nanotechnology applications have new properties unavailable in bulk materials. The synthesis, processing, and characterization of these materials require a facility with concepts beyond those needed for typical engineering materials. This minor requires 15 credits selected from the lists below.

Required Courses

I Basics of Nanotechnology

MAT 355. Materials for Nanotechnology (3)

II Crystallography and Band Theory

Choose one of the following four courses:

Course		Pre-requisites
MAT 302	Electronic Properties of Materials (3)	MAT 201
PHY 363	Physics of Solids (3)	CHM 187, 341; PHY 340
ECE 308	Physics and Models of Electronic Devices (3)	ECE 126
CHM 341	Chemical Physics and Bonding (4)	CHM 187

Elective Courses

Elective courses are to be selected from the list below. New courses will be added to this list as they are created. There will be additional courses made available by distance learning from the MatPAC universities. MatPAC is the Materials Pennsylvania Consortium.

Course		Pre-requisites
STS 198	Nanotechnology and Society (4)	
CHE 391	Colloid and Surface Chemistry (3)	CHM 31, CHM 187
CHM 488	Advanced Topics – Surface Chemistry (Bruce Koel)	
MAT 334	Electron Microscopy and Microanalysis (4)	
MAT 359	Thin Films (3)	
MAT 345	Powder Metallurgy (3)	MAT 206
MAT 356	Strategies for Nanocharacterization (3)	
PHY 369	Quantum Mechanics I (3)	PHY 31, PHY 215
PHY 372	Nano-systems in 1-D (Slava Rotkin) to be given only in alternate fall semesters (odd years)	
ECE 126	Fundamentals for Semiconductor Devices (3)	ECE 81 or equivalent
ECE 325/ 425	Semiconductor Lasers I (3)	ECE 203
ECE 337	Intro. To Micro- and Nanofabrication (3)	MAT 33 or ECE 351
ECE 450	Nanoelectronics (Marvin White)	
ECE 338	Quantum Electronics (3)	ECE 203
ECE 351	Microelectronics Technology (3)	ECE 126

Additional requirement: Since the aim of this minor is to provide an interdisciplinary program in nanotechnology, students must take at least two courses outside their home department. Courses of individual study (including laboratory projects) on relevant topics, in any appropriate department, will also be accepted as electives for the minor, with the approval of the advisor.

c. Minor in Materials (for students in other disciplines)

To obtain a minor in Materials Science and Engineering, a student must complete one required course (MAT 33, 3 credits) and four other three-credit courses from a list given below, for a total of 15 credit hours. See appendix 1.

Some General Rules that Apply to All Minors

1. The minimum number of credits for a minor is 15. However, many minors may require more in practice, because of the specific requirements of the program.
2. It may be possible for a course to contribute to both the requirements of the major and to the requirements for the minor.
 - a. At most one required course of the major may contribute to the minor.
 - b. Approved electives, engineering electives, technical electives etc. may be used to take courses that contribute to the minor, provided that the courses are on the corresponding list for the major.
 - c. Free electives (and, in some cases, courses to meet the HSS requirement) can be used as courses needed for the minor.
3. Courses that are cross listed between the departments of the major and the minor may not be taken as contributing to the requirements of the minor, unless a specific exception is made in the program.
4. A 2.0 minimum grade-point average is required for courses in the minor. Because of this requirement, no course in the minor program may be taken with Pass/Fail grading.
5. It is the responsibility of the student desiring a minor to complete a formal registration for the minor in the department, division, or program where it is offered. Officially, this may be done at any time up to the time of registration for the student's final semester. However, it is strongly recommended that the registration for the minor be completed as early as possible. Preferably, no later than the beginning of the junior year (and some programs may have this as a requirement). The student's minor advisor maintains appropriate records.

Requirements for a Minor in Materials Science and Engineering

Minor in Materials Science and Engineering

To obtain a minor in materials science and engineering a student must complete at least 15 credit hours of materials science and engineering as follows:

REQUIRED COURSE:

MAT 33 Engineering Materials and Processes (3)

ELECTIVES:

MAT 10 may be used as an elective. The remaining courses to complete the minor may be any 200-level or 300-level courses offered by the Department of Materials Science and Engineering, with the exception of the following courses which are excluded: MAT 221; MAT 240; MAT 291; MAT 327; MAT 329; MAT 338.

Requirements for a Minor in Chemical Engineering

Chem E. Minor for Materials Science & Engineering Students

To obtain a minor in chemical engineering within the materials science and engineering undergraduate curriculum, an MS&E major must complete five courses as follows:

REQUIRED COURSES:

ChE 31	Material and Energy Balances of Chemical Processes (3)
ChE 44	Fluid Mechanics (4)
ChE 151	Introduction to Heat Transfer (3)
ChE 210	Chemical Engineering Thermodynamics (4)
ChE 211	Chemical Reactor Design (3)

ELECTIVES:

ChE 201	Methods of Analysis in Chemical Engineering (3)
ChE 242	Introd. To Process Control and Simulation (3)
ChE 244	Mass Transfer and Separation Processes (3)
ChE 321	Fundamentals of Air Pollution (3)
ChE 341	Biotechnology I (3)
ChE 342	Biotechnology II (3)
ChE 391	Colloid and Surface Chemistry (3)
ChE 392	Introduction to Polymer Science (3)

Note:

Students taking the ChE minor can replace ChE 60 with a free elective.

Requirements for a Minor in Manufacturing Systems Offered by the Department of Industrial and Systems Engineering

Minor in Manufacturing Systems Engineering

To obtain a minor in manufacturing systems engineering a student must take at least 16 credit hours. A student must take a required course from each of 4 areas and 2 elective courses from a general list.

REQUIRED COURSES:

Computer Graphics Requirement:

IE 112 Computer Graphics (1) or
ME 10 Graphics for Engineering Design (3) or
CE 15 Graphics for Civil Engineering (3)

Probability and Statistics Requirement:

Math 231 Probability and Statistics (3) or
IE 328 Engineering Statistics (3) or
IE111 Engineering Probability (3) and
IE 121 Applied Engineering Statistics (3)

Manufacturing Processes:

IE 215 Fundamentals of Modern Manufacturing (3)
MAT 206 Processing and Properties of Metals (3) or
ME 240 Manufacturing (3)

Production Analysis:

IE 168 Production Analysis (3)

ELECTIVES:

At least 2 elective courses from the following list:

IE 131 Work Systems and Facilities Planning (3)
IE 319 Material Handling and Facilities Planning (3)
IE 324 Industrial Automation and Robotics (3)
IE 332 Quality Control (3)
IE 334 Organizational Planning and Control (3)
IE 340 Production Engineering (3)
IE 342 Computer Integrated Manufacturing (3)
IE 344 Metal Machining Analysis (3)
IE 347 Electronics Manufacturing (3)

Requirements for a Minor in Mechanics of Materials Offered by the Department of Mechanical Engineering and Mechanics

DESCRIPTION:

The minor in mechanics of materials provides a view of mechanical strength and behavior of materials based on understanding of a few basic concepts and using simplified material models. Courses selected for the minor emphasize concepts such as superposition of loadings; relation between external loads and internal stresses; factor of safety; safe design based on allowable stress or allowable loads; allowable deformation; and reliability of structures. Courses offer a wide variety of topics including analytical and numerical methods for solving mechanics problems; manufacturing and polymer processing. The mechanics of materials minor requires a minimum of 15 credits, which must be taken from MEM offerings. Two courses are required; and three additional electives must be selected. The minor is not available for students having a major in the Department of Mechanical Engineering and Mechanics.

REQUIRED COURSES:

MECH 3 (3)	Fundamentals of Engineering Mechanics
MECH 12 (3)	Strength of Materials

ELECTIVES:

ME 10 (3)	Graphics for Engineering Design
ME 215 (3)	Engineering Reliability
ME 240 (3)	Manufacturing
ME 252 (3)	Mechanical Elements
ME 344/MAT 344/IE 344*	Metal Machining Analysis
ME 385 (3)	Polymer Product Manufacturing
MECH 102 (3)	Dynamics
MECH 305 (3)	Advanced Mechanics of Materials
MECH 312 (3)	Finite Element Analysis
MECH 313 (3)	Fracture Mechanics

* This cross-listed course ME 344 counts as an elective.

Notes:

ME 10 is a prerequisite for ME 240 and subsequently ME 344.

MECH 102 is a prerequisite for ME 252.

Interested students should contact the Mechanical Engineering Department

It would be helpful to deposit a copy of the completed paperwork in the Materials Science and Engineering department office as well.

Requirements for a Minor in Polymer Science and Engineering

(polymer manufacture, physical and chemical properties, composite materials, polymer colloids, polymer applications, etc.)

To earn a minor in Polymer Science and Engineering, a student must register for at least 15 credits of coursework distributed as follows:

REQUIRED COURSES:

Chm 51	Organic Chemistry I
Chm 187	Physical Chemistry or MAT 33 (for chemistry majors)
MAT 204	Processing and Properties of Polymeric Materials

ELECTIVES: (select two)

MAT 309	Composite Materials – Fall semester – senior year (Prerequisite: Mat 33, Mech 2, senior standing)
MAT 334	Electron Microscopy and Microanalysis – Fall semester – senior year (Prerequisite: Permission and senior standing)
ChE 388	Polymer Synthesis and Characterization Laboratory – Fall semester – senior year (Prerequisite: senior standing)
ChE 391	Colloid and Surface Chemistry – Spring semester – senior year (Prerequisite: Chm 187 and senior standing)
ChE 392	Introduction to Polymer Science – Fall semester – senior year
ChE 393	Physical Polymer Science – Fall semester – senior year (Prerequisite: senior standing)
Chm 394	Organic Polymer Science I – Spring semester – senior year (Prerequisite: see course catalog)

The IBE Degree and Accreditation

The B.S. Degree in Materials Science and Engineering is an “accredited” degree. This means that it is recognized as satisfying one requirement for the Professional Engineering (PE) license. For some careers and some professional activities, it is a requirement to hold the Professional Engineering license. Indeed, in Pennsylvania, you may not have “engineer” in your job title unless you have the PE license.

The Integrated Business and Engineering (IBE) degree is not an accredited engineering degree and will not, therefore, serve towards the acquisition of PE status.

Those who elect to take IBE have been and will be explicitly warned that the degree will not lead to PE. However, it is possible that students will change their minds and wish to get, in addition to the IBE, a regular engineering degree in order to go on to the PE.

In order to obtain an accredited engineering degree, a student would have to complete the set of courses needed for our normal BS in Materials Science and Engineering. The courses that are required for the BS in Materials Science and Engineering but are not included in the IBE degree amount to 23 credits. However, Lehigh has a general rule that says that a person may not obtain a second degree with fewer than 30 additional credits.

Therefore to obtain the accredited degree as well as IBE, a student would have to take courses summing to 30 additional credits (23 credits of the materials program courses, not included in IBE, plus additional credits in any courses of the student’s choice).

Curriculum for an IBE Major in Materials Science and Engineering
(as of 5/09)

Total credits required for graduation: 137

All IBE students must fulfill standard IBE requirements including:

- Foreign language proficiency
- One summer internship
- Maintenance of a minimum 3.25 GPA

Freshman Year

Fall Semester		Spring Semester	
Engl 1	3	Engl 2	3
Math 21	4	Math 22	4
Chem 25	4	Phys 11	4
IBE 10	1	Phys 12	1
Engr 1	3	Comm 130/160 or SSP 135	4
		IBE 50	3
Total Credits	15	Total Credits	19

Sophomore Year

Fall Semester		Spring Semester	
Mat 33	3	Acct 151	3
Phys 21	4	Eco 129	3
Phys 22	1	Mat 203	3
Math 23	4	Mat 205	3
Eco 1	4	Mech 2	3
Mat 10	2	HSS Elective	3
IBE 150	1		
Total Credits	19	Total Credits	18

Junior Year

Fall Semester		Spring Semester	
Acct 152	3	Math 205	3
BIS 111	3	Fin 125	3
Mat 216	3	Mkt 111	3
Mat 218	3	ECE 81	4
HSS Elective	3	Mat 20	2
IBE 250	1	IBE 380	3
Total Credits	16	Total Credits	18

Senior Year			
Fall Semester		Spring Semester	
Law 201	3	Mgt 243	3
IBE 385	3	Free Elective	3
IE 328 or Math 231	3	Eco 146	3
Mat 201	3	ChE 60	3
Free Elective	3	Mat 204, 206, 214, or 302	3
Free Elective	3		
Total Credits	18	Total Credits	15

MS&E Dual Degree Option

Courses required for the BSMS&E degree not taken by IBE MS&E Majors:

Credits	Course	Description	Semester	Prerequisites
9	(Remaining 3 of 4)			
	Mat 204	Polymers	S	Mat 33
	Mat 206	Metals	S	205, Mat 216, Mat 33
	Mat 214	Ceramics	S	Mat 203
	Mat 302	Electronic	F	Mat 201
2	Mat 101	Professional Development	F	
3	Mat 338	Materials Selection and Failure Analysis	S	Mat 204, 206, 214, 218
6	Engin. Sci. Elective	See options in catalog		
3	Approved Elective	See options in catalog		
7	Free Elective			

30 Total Credits

To complete the BSMS&E Dual degree program, students must:

- Take the above “Courses required for the BSMS&E degree not taken by IBE MS&E Majors”
- Complete at least 165 total credits (MS&E degree requires 135 + 30 more credits from the “30 credit rule”)
- Fulfill the HSS “8 credits in 1 department” rule (e.g., by taking at least 1 more credit of Eco)

If the student takes SSP 135 (rather than Comm 160 or 130) the student must take 3 credits of humanities in their HSS electives (to fulfill the rule of at least 3 credits of Humanities)

Dual degree students should use IBE free electives to take “Courses required for the BSMS&E degree not taken by IBE MS&E Majors”.

Integrated Degree – Engineering, Arts & Sciences (IDEAS) (as of 5/09)

IDEAS is a four-year honors program, resulting in a Bachelor of Science (BS) Degree, **Integrated Degree in Engineering, Arts, & Sciences (IDEAS)**, jointly administered by the College of Arts & Sciences and the P.C. Rossin College of Engineering & Applied Science.

Entry Requirements:

1. Admitted students in the Class of 2013 who have expressed interest when applying, will be considered for the IDEAS program; only a limited number of students will be accepted. Students are accepted into this honors program by invitation.
2. To remain in the IDEAS program, students must maintain a 3.25 GPA. At the end of the first year, a student with a GPA below 3.25 is given two semesters to achieve a GPA of 3.25; otherwise the student would be asked to transfer to a regular degreed program in arts and sciences or engineering.
3. Students may transfer into the IDEAS program at the end of their first semester or year if space becomes available. A formal application to the program must be filed, and approval must be obtained from the co-directors.
4. Students who are interested in the IDEAS program should contact one of the co-directors at any time prior to or after making application to Lehigh.

The IDEAS program is designed so that students who transfer out of the program at the completion of the first year will still be able to complete an arts, science, or engineering degree in four years. The four year IDEAS program does not lead to an ABET accredited engineering degree. It is possible for students to complete a BS degree in IDEAS and an ABET-accredited BS engineering degree (dual degrees) in one or two additional semesters.

Term-by-Term Sample for the IDEAS Program:

First Year

Fall

IDEA 11	IDEA Seminar I
Math 21	Calculus I
Physics 11/12	Physics I
Arts & Science	Concentration Course

Spring

IDEA 12	IDEA Seminar II
Math 22	Calculus II
Chem 25	Intro Chem Principles
Arts & Science	Concentration Course
Engr	Major Course

Sophomore Year

Fall

IDEA 111	IDEA Seminar III
Math 23	Calculus III
Chem 31	Chem. Aqueous Sys
Arts & Science	Concentration Course
Engr	Concentration Course

Spring

IDEA 112	IDEA Seminar IV
Math 205	Linear Methods
Phys 21/22	Physics II & Lab
Arts & Science	Concentration Course
Engr	Concentration Course
Elective	Elective

Junior Year

Fall

IDEA 150	IDEA Project
Chem 51	Organic Chemistry
Arts & Science	Concentration Course
Engr	Concentration Course
Engr	Concentration Course

Spring

Arts & Science	Concentration Course
Arts & Science	Concentration Course
Engr	Concentration Course
Engr	Concentration Course
Elective	Elective

Senior Year

Fall

IDEA 210	IDEA Senior Thesis
Arts & Science	Concentration Course
Engr	Concentration Course
Engr	Concentration Course
Elective	Elective

Spring

Arts & Science	Concentration Course
Engr	Concentration Course
Engr	Concentration Course
Engr	Concentration Course
Elective	Elective

Total

136

Notes:

1. Each year, one 3-credit IDEAS core course is required, and an average of one 4-credit elective block course is taken.
2. Each of the 36-credit **Math/Science**, **Arts & Sciences**, and **Engineering** blocks require an average of one 4-credit course per semester plus an additional 4 credits.
3. Engineering major courses are usually 3 credits.

Prerequisites

Lehigh University rules state that a grade of D+, D or D- is a pass but is not “adequate to take any subsequent course which has this course as a prerequisite.” Therefore any student who gets a D, F or W on a course must take it again if the course is a prerequisite for a course to be taken later.

In the Department of Materials Science and Engineering it is the policy that a professor has the right to waive a prerequisite for a course they teach. In particular, a student with a D in a course may be allowed, at the discretion of the professor, to take a course for which the D course is a prerequisite. Normally, in order to waive the prerequisite, the professor will require that the student demonstrate competence, by taking a test (prior to starting the course) or by meeting some other conditions set by the professor. If a student negotiates conditions to be met for the waiver of a prerequisite, a written record of what is agreed must be left in the Department office. The Department will accept waivers of prerequisites only when the student file contains a statement indicating that the professor’s conditions have been met.

Summary

A student’s advisor may not waive a prerequisite.

The professor of the course may waive a prerequisite at his or her discretion. If no conditions are linked to the waiver, the professor must sign a prerequisite waiver form at the time.

If conditions are imposed (e.g. I will give you a test on this material.) the conditions must be confirmed in writing (email acceptable) and a paper copy placed in the student file at the time the conditions are set.

Undergraduate Student Overload Policy **for students planning on taking 19 or more credits** (current as of 4/06)

The normal course load for a Lehigh undergraduate is 14 to 17 credits. Full-time status requires at least 12 credits. Students are urged to avoid part-time status without careful consideration of the consequences, which may include loss of eligibility for financial aid, participation in sports or other extracurricular activities, veterans' or other benefits, university housing, and certain family or group medical insurance plans.

Students are also urged to avoid a course-credit overload (19 or more credits). The nominal workload expectation is about 3 or 4 hours per week per credit, in addition to time spent in class. Overloading adds to demands on the student's time, and often, the result is less time spent on each course rather than more time spent on coursework overall. Adding more courses to the student's roster reduces the student's ability to focus the concentrated effort required to learn deeply. Coursework should be the student's highest priority for allocating time, but Lehigh is a rich experience with opportunities for student development on other dimensions besides academics. Indeed, students who participate in extracurricular activities and cultural events, who get involved in community activities, who maintain connections with friends and family, and who read newspapers, magazines, and for pleasure are happier, more well-rounded people who learn more and earn better grades. Having time to allocate to such leisure activities provides for much-needed rest and relaxation, lowers stress, keeps work in perspective, and engages the student in personal development beyond academics. Experience also shows that, even for the very best students, overloading increases the risk of lowering the student's GPA or otherwise impeding academic progress. Finally, overloading increases the demand for resources, in particular faculty and staff effort and space in classes, which compromises the quality of the educational experience for all students and may reduce access to limited enrollment courses. For all of these reasons, Lehigh has adopted a policy of constraining overloads.

Overload: The normal course load in all colleges is 14-17 credit hours (15-18 in the College of Engineering and Applied Science), encompassing 4-5 primary courses.

Overload Limitations:

- 1. Overload approval will not be granted for the purpose of repeating a course.**
- 2. No overload approval will be granted in a semester where the student is enrolled in a graduate course.**
- 3. Any course(s) approved for overload cannot be added until after the end of the normal (three week) registration period. Space in a course cannot be reserved for students intending to add the course as an overload.**

Overload approval requirements vary by GPA and entry into the University. Typical loads are 14 to 17 credits. 18 credits is an overload for first semester students and for

students with a GPA below 2.5. 19 credits is an overload for all other students. Overload rules by grade point average are below:

First semester students:

18-19 credits, Associate Dean
20 or more, SOS

GPA 2.5 or below:

18 credits, Associate Dean
19 or more, SOS

GPA between 2.5 and 3.3:

19 credits, Associate Dean
20 or more, SOS

GPA 3.3 or above:

19-20 credits, Associate Dean
21 or more, SOS

Undergraduates that have been approved for an overload (greater than 18 credit hours) will not be permitted to register for the overload course and credits until **after** the regular advanced registration period has ended. As a rule of thumb, that will be three weeks after the registration period begins.

If you have been informed by the appropriate University official (in most cases the Associate Dean of your college) that your overload request has been approved, you will have your credit-hour maximum increased. After that time you will be able to web register for the overload course. Keep in mind that having approval for an overload **does not** guarantee availability. This is on a space available basis only. Procedures for special section registration procedures and approvals remain in place.

For all students with a GPA that requires dean and advisor approval and SOS approval, as noted in the chart above, a full petition to that committee must be submitted by the last day to drop/add in the Fall or Spring for the following term.

B. Other

Department Awards

The Department of Materials Science and Engineering offers the following undergraduate student awards.

Bradley Stoughton Student Award (Spring)

- Given to an outstanding senior in the Materials Science and Engineering Department.

Kahn Memorial Award (Spring)

- Given to a senior outstanding in materials science and engineering.

Cyril John Osborn Award (Spring)

- Given to a senior who shows outstanding promise of a successful career in materials science and engineering.

Allen S. Quier Prize (Spring)

- Given to the senior adjudged by the staff of materials science and engineering to have made the most progress in that curriculum.

Handwerk Prize (Spring)

- Given to a senior for outstanding achievement in the fields of chemistry, materials science and engineering or earth and environmental sciences.

Tarby Prize (Fall)

- Given to a junior for achieving the best academic performance during the first two years at Lehigh.

Gilbert Doan Award (Spring)

- Given to a sophomore for outstanding performance in academics and work-study activities.

Harmer Prize (Spring)

- Citizenship Award which is given to a sophomore, junior or senior.

Allison Butts Award (Spring)

- Given to a sophomore, junior or senior to support attendance at technical meetings or participation in overseas study.

Student Materials Society (SMS)

OVERVIEW

The Student Materials Society is comprised of the student body in the Materials Science and Engineering Department. SMS is an organization recognized by national societies such as ASM International, TMS, Materials Advantage.

PURPOSE

The goal of SMS is to provide a social and educational supplement to the standard academic coursework of the Materials Department.

LEADERSHIP

Four officer positions and a faculty advisor comprise the leadership of the organization. These include the President, Vice President, Treasurer and Secretary. The terms are one year with exception of the faculty advisor. Terms begin at the end of each school year, generally in the month of April. All students in junior standing are eligible for officer positions, making their term the majority of their senior year.

EVENTS

The Student Materials Society has the opportunity to plan many different types of events for the Materials Science and Engineering Department. The officers are in charge of planning events, and all the associated particulars of each event (time, location, cost, etc.) Typically these events include but are not limited to: fall barbeque, winter banquet, spring barbeque and graduate school information sessions. As shown by the list, events can be social, educational or anywhere in between. Depending on the event, it could be attended by people in the materials department only or by the entire student body.

FUNDING

There are various sources of funding for SMS, one of which includes a yearly allowance from the Lehigh University Student Senate of \$350.00. This funding must be used each year, indicating activity of the society or it will be withdrawn by the Student Senate. In addition, SMS receives a small sum for each member of both SMS and Materials Advantage/ASM/TMS (from Materials Advantage/ASM/TMS). Another source of funding includes charging for various activities and events.

Lehigh Microscopy School

In June of each year, approximately 150 people attend microscopy courses in our department during the Lehigh Microscopy School. These courses, begun in 1970 by former Professor Joe Goldstein, provide people from industry with the fundamentals and advanced techniques of scanning electron microscopy, analytical transmission electron microscopy, microanalysis, and scanning probe microscopy. In some places in the world, Lehigh is known primarily through these courses and other activities related to electron microscopy. A typical brochure for these courses is shown on the following pages.

If you plan to be in the area at the end of May and, in the first two weeks of June, you may be able to earn a little money helping with these courses.

C. Some words of advice from the faculty “in loco parentis”

Words of Fatherly and Motherly Advice

1. Choosing HSS courses
2. Choosing Electives
3. Troubles

1. Choosing HSS courses

The range of choices for your HSS courses is enormous. How to decide which courses to select can be a daunting prospect. We would like to suggest that you take the following factors into account.

First and most importantly, take courses that are interesting to *you*. Do not take courses only because you have friends taking them. Their interests may not be the same as yours. The HSS courses, you take should give you pleasure.

Second, consider the impact on your career. For example, if you expect to get a job that will take you to the Middle East, consider courses in Arabic or Muslim studies.

Finally, among the rules that govern HSS is the “depth” rule. This says that you must take at least eight credits (including three credits at the 100 level or above) in the same department or program. You should give special thought to the subject you choose for these courses. We suggest that you take a course in the subject you plan to use for your depth requirement early on. In this way, if you find you do not like the subject after all, you will still have time to find another subject.

2. Choosing Electives

In choosing the Engineering Science Electives, the Approved Elective, and the Free Electives, the way you make the choice is very similar to the way you choose HSS courses. Generally, you should choose things you find interesting and things that you expect to help in your career. These courses are taken towards the end of your studies. This should make it easier to make the choices, because you will be more familiar with the system. Please, note that, in the case of the Engineering Science Electives and the Approved Electives, not all of the listed courses will be available at the time you might want to take them. Among the elective courses, many may be given only every second year (or even less frequently). If there are particular courses you would like to take, it would be wise to contact the professor concerned as early as you can to be sure of its availability. You would not want to plan your studies only to find that a course you were relying on will not be given.

3. Troubles

Almost all students go through difficult times. It is very common to go through weeks or months when your studies are not up to the level they could and should be. Periods of emotional problems (depression, frustration, anger and so on) are quite normal. Many students are faced with problems unrelated to their studies: financial or family problems, for example.

All of this is normal. It is to be expected. You will be fortunate if you complete your time at Lehigh without such a period. However, most students work through these troubles and finish their studies successfully.

Our fatherly and motherly advice on this topic is this. When troubles start, do not ignore them or just wait for them to go away. As soon as you are aware of a problem, get help. The worst mistake you can make is (perhaps out of pride or embarrassment) to delay getting help. Help is available in many places and in many forms. Depending on the nature of the problem, you should talk to one of the following before the problem gets serious. There is no shortage of people to offer you assistance.

The professor
Your advisor
The Chair or Associate Chair of the Department
The counseling service
Gryphons
Residence life coordinators
The Dean of Students' Office
The Lehigh ombudsman
The harassment officer
Your parents
The University Chaplain
Your religious mentor (priest/rabbi/etc).