



Generation of Coherent Microwave/ Millimeter-Wave Radiation

- Photoconductively-switched antennas & rectifications: broadband pulses
- Optical mixing in photodiodes, MESFETs, HEMTs, HBTs, Schottky diodes: up to 100 GHz
- Klystrons & backward-wave oscillators: bulky & short lifetimes

This Presentation

- Generation of monochromatic microwave/ millimeter-wave radiation with output frequency continuously tunable in a large range (53-300 GHz) by mixing two optical frequencies in a GaSe crystal

Our Recent Work

- Experimental Results on GaSe**
Tuning range: 58.2 μm – 3.54 mm
Highest peak power: 209 W @ 196 μm
Line width: 0.2 cm^{-1} @ 196 μm
- Experimental Results on ZnGeP₂**
Tuning range: 83.1 μm – 1.64 mm (type I)
80.2 μm – 1.42 mm (type II)
Highest peak power: 134 W @ 237 μm
- Experimental Results on GaP**
Tuning range: 71 μm – 2.83 mm (parallel)
71 μm – 0.808 mm (orthogonal)
Highest peak power: 15.6 W @ 173 μm

Shi & Ding, Opt. Lett. (2002); Opt. Photon. News (2002); Appl. Phys. Lett. (2003); Opt. Commun. (2004); Appl. Phys. Lett. (2004); Opt. Lett. (2005)

First Experimental Setup

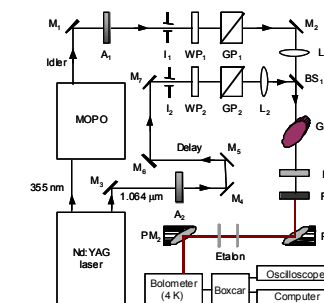

GaSe Single Crystals

- Negative uniaxial $n_o > n_e$ (anomalously large birefringence)
- Transparency range: 0.62-20 μm
- Nonlinear coefficient: $d_{22} \approx 54 \text{ pm/V}$
- Among all commonly-available nonlinear crystals, GaSe has lowest absorption coefficient in microwave/millimeter-wave region, e.g. $\alpha_e \approx 0.015 \text{ m}^{-1}$ at wavelength of 6 mm (frequency of 50 GHz or 1.67 cm^{-1})

Absorption Spectra for GaSe

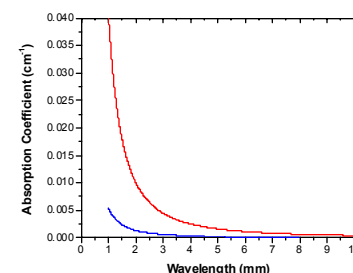

- Absorption for ordinary wave (red curve) is much larger, especially near high-frequency end

Output Wavelength vs. External Angle for GaSe

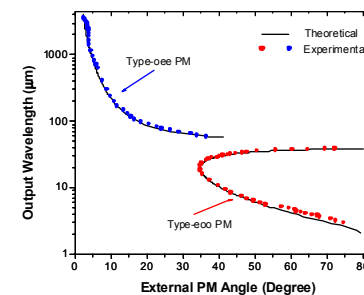

Measurement of Wavelength Using Ge Etalon

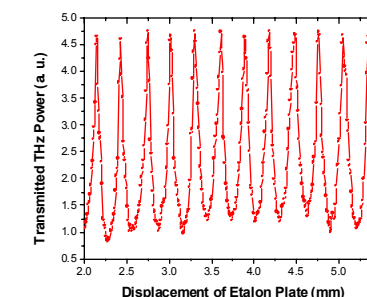

Measured wavelength: 600 μm

Output Power vs. Wavelength for GaSe

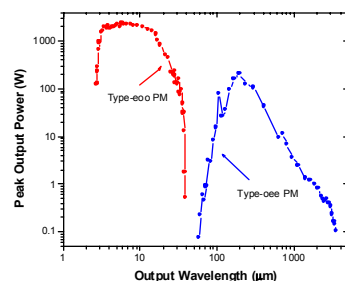

Output Peak Power vs. Wavelength

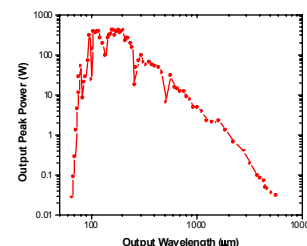

- 66.5 μm (150 cm^{-1}) to 5.66 mm (1.77 cm^{-1}); 389 W at 203 μm ; conversion efficiency $\sim 0.1\%$ – widest tuning range, highest peak power & conversion efficiency for tabletop system!
- Peak power of 1 kW – feasible!

Microwave/ Millimeter-Wave Range

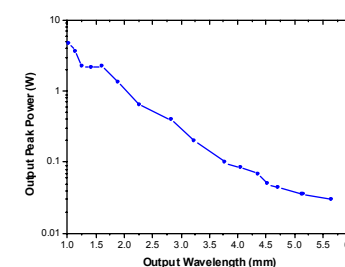

- At wavelength of 1 mm (300 GHz), output peak power of 4.7 W; power conversion efficiency $\approx 0.0012\%$ (photon conversion efficiency $\approx 1.3\%$)

Wavelength Tuning (oe-e)

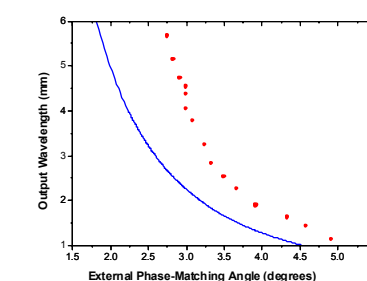

- Significant deviation between data (red dots) and calculations (blue curve) – visible

Effect of Pump-Wavelength Fluctuation on Output Power

- For phase-mismatch of $\pi/2$, microwave power drops to 81% of phase-matched value; deviation of pump frequency $\approx 5.0 \text{ GHz}$ for crystal length of 4.7 cm & wavelength of 1.1 mm

Frequency fluctuation of pump beam must be much smaller than 5 GHz!

Effect of Fluctuation of Incident Angles on Output Power

- Assuming phase-mismatch for difference-frequency generation $-\pi/2$, deviation of external incident angle $\approx 0.035^\circ$

Diffraction angle for pump beam must be smaller than this value

- To achieve optimum conversion, confocal beam parameter for microwave/millimeter-wave \approx half of crystal length

Diffraction angle $\approx 0.0030^\circ$ for output wavelength of 1.1 mm & crystal length of 4.7 cm

Beam radius for pump beams $\approx 2.3 \text{ mm}$

Conclusion

- Based on difference-frequency generation in GaSe, output wavelengths & frequencies are continuously tuned in microwave/ millimeter region:

✓ 1 mm – 5.66 mm (300-53 GHz)
4.7 W @ 1 mm (300 GHz)
Photon conversion efficiency: 1.3% (0.0012%)

- Advantages: high coherence (monochromatic), simplicity for tuning, easy alignment, stable output powers & wavelengths
- Effects of fluctuations of pump wavelengths and incident angles on output power – investigated
- Scaling up powers – possible using novel structures (e.g. output power of 160 W for pump power of 100 kW)

Applications

- To achieve coherent links between optical and microwave frequency standards
- To study molecular rotational transitions
- To construct microwave-photonics devices & systems