

Lehigh University Center for Optical Technologies

Viscoelastic Behavior of Optoelectronic Adhesives

PIs: Guy Connelly and Ray Pearson

Project Status: Phase 1.0 Completed - Phase 2.0 Starts May 15, 2003

MOTIVATION

Misalignment Due to Adhesives

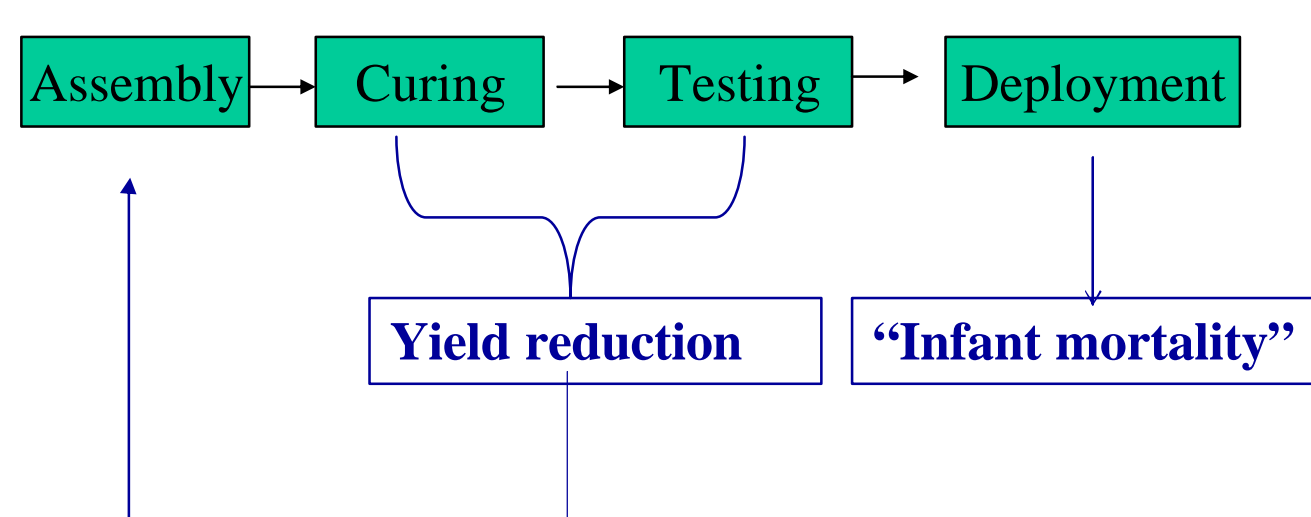

- Adhesives: the main factor to module instability and misalignment loss
- Low yield and throughput major contributors to high cost of modules
- Cost especially important in metro where most growth and high volume production is expected

BACKGROUND

Project Objectives

- To develop a knowledge and database system enabling materials selection for assembly of dimensionally stable optical and optoelectronic modules.
- Improve yield, reliability, throughput, cost
- Enable automation
- The project is designed as pre-competitive
- Develop longer range strategy for packaging focus in Opto-electronics
- Encourage new membership in the optical domain

Expected Benefits

- Reduce replication of effort
- Identify critical properties
- Encourage materials development
- Assist materials selection

Viscoelastic Behavior of Adhesives

- Standard cured "elastic" properties T_g , CTE, E , G , n
- Viscoelastic data to be reported $E(t, \dot{\gamma})$ or $G(t, T)$

Standard linear solid

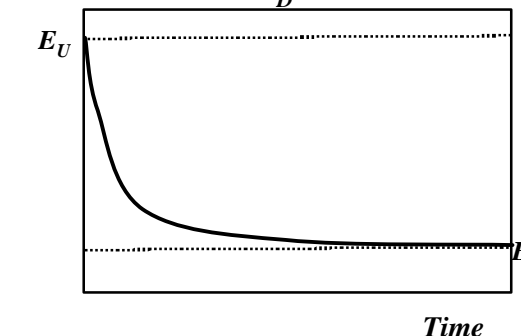
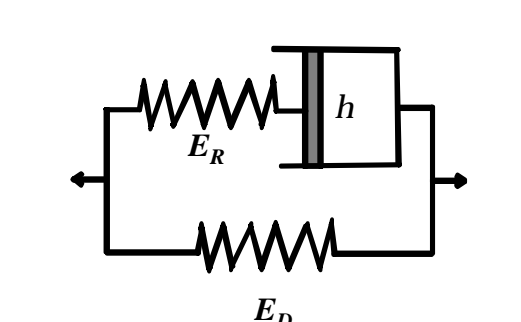

Shape recovery after cycle

4 element model

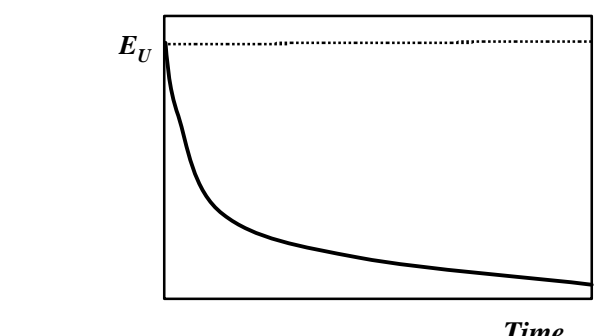
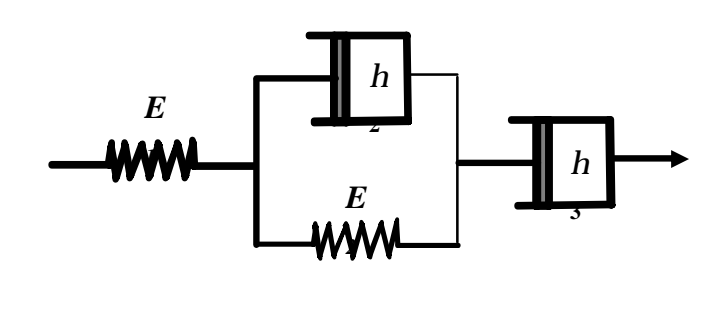

Irreversible deformation

APPROACH

Viscoelastic Tests

Four Types of Viscoelastic Tests:

- Linear Scaling Test
 - $G(\text{strain, temp.})$
- Dynamic Mechanical Analysis (DMA)
 - $G(\text{temp., freq.})$
- Stress Relaxation
 - $G(\text{time})$
- Creep Tests (multiple steps)
 - strain versus time

RESULTS

DMA Results

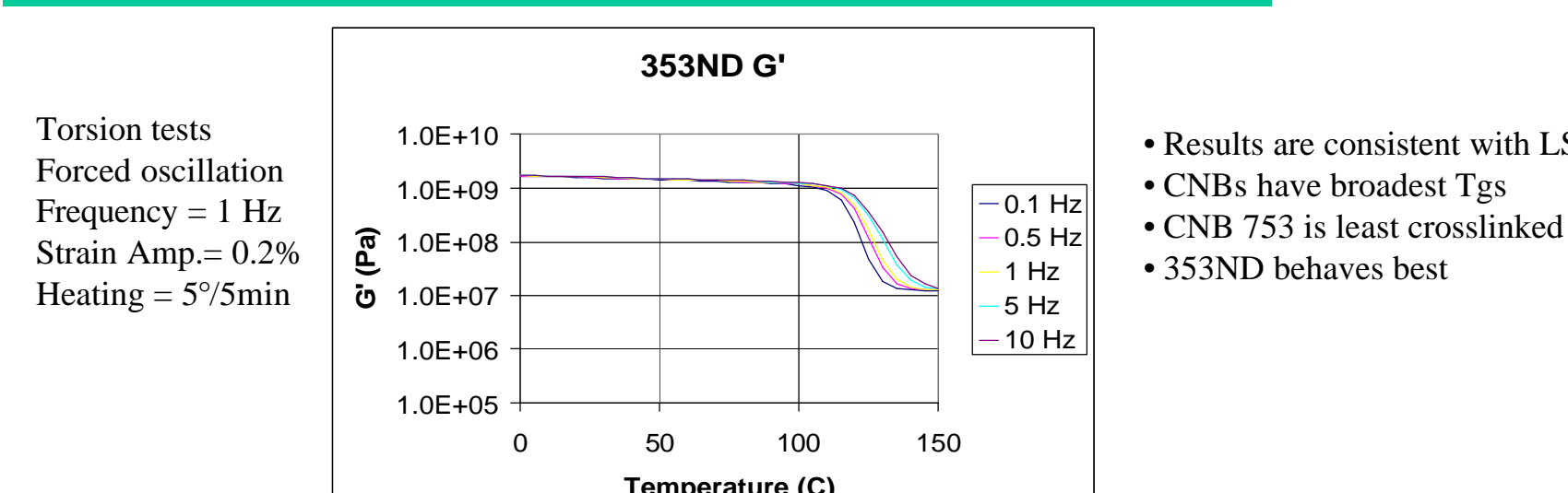

- Results are consistent with LS
- CNBs have broadest T_g s
- CNB 753 is least crosslinked
- 353ND behaves best

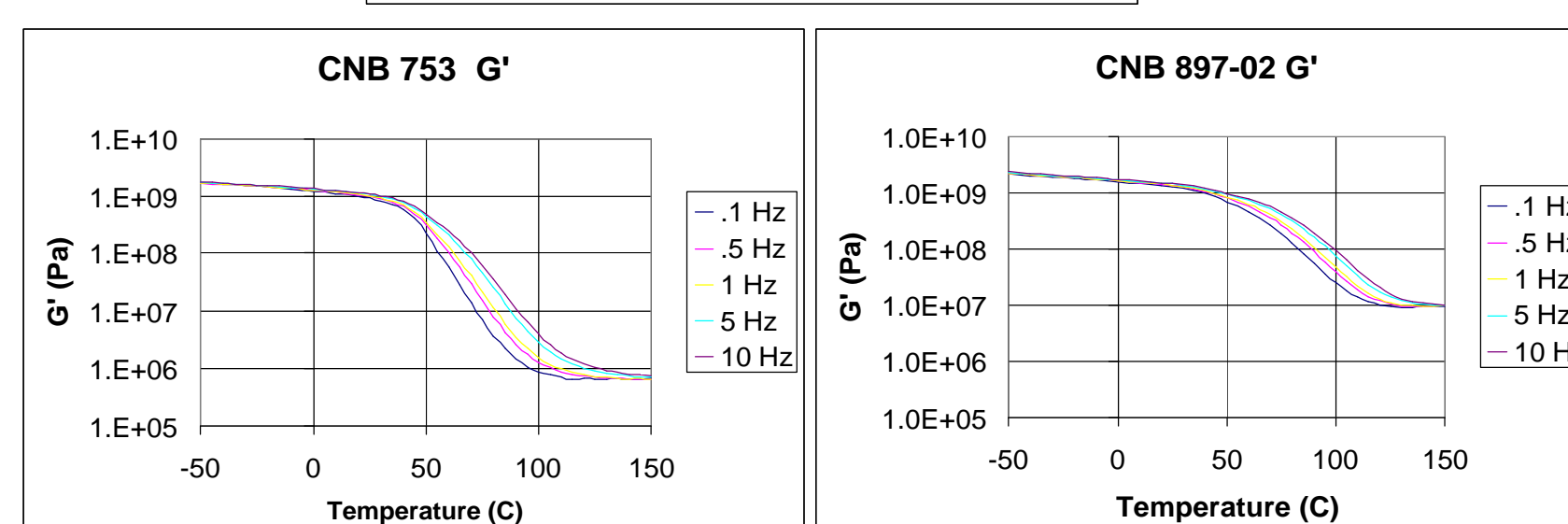

Stress Relaxation Results

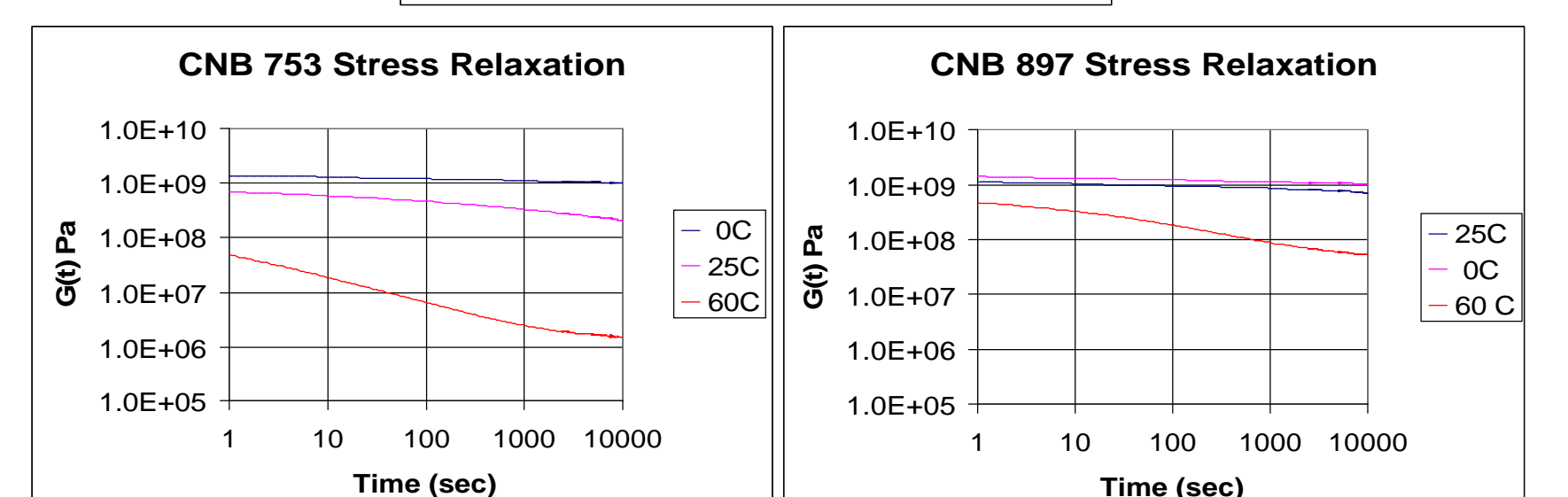
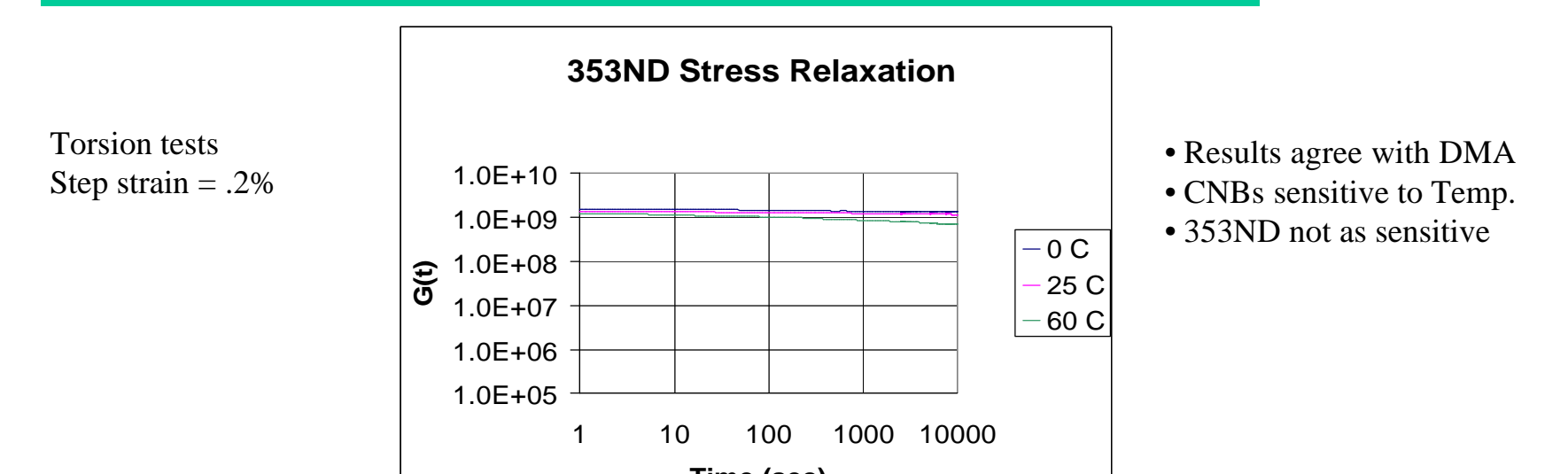

DISCUSSION

Summary

- Three adhesives were characterized
 - Epo-Tek 353ND (epoxy-based)
 - Hysol CNB 753 (acrylic-based)
 - Hysol CNB 897-02 (acrylic-based)
- Four viscoelastic tests were performed
 - Epoxy better than acrylics tested
- Is time dependent plasticity an issue?
 - Stress relaxation tests do NOT support presence of plasticity
 - Stress relaxation tests allow materials to reach equilibrium
 - Creep tests drive polymers to non-equilibrium states
 - Unfortunately, our creep tests need more refinements

Modeling

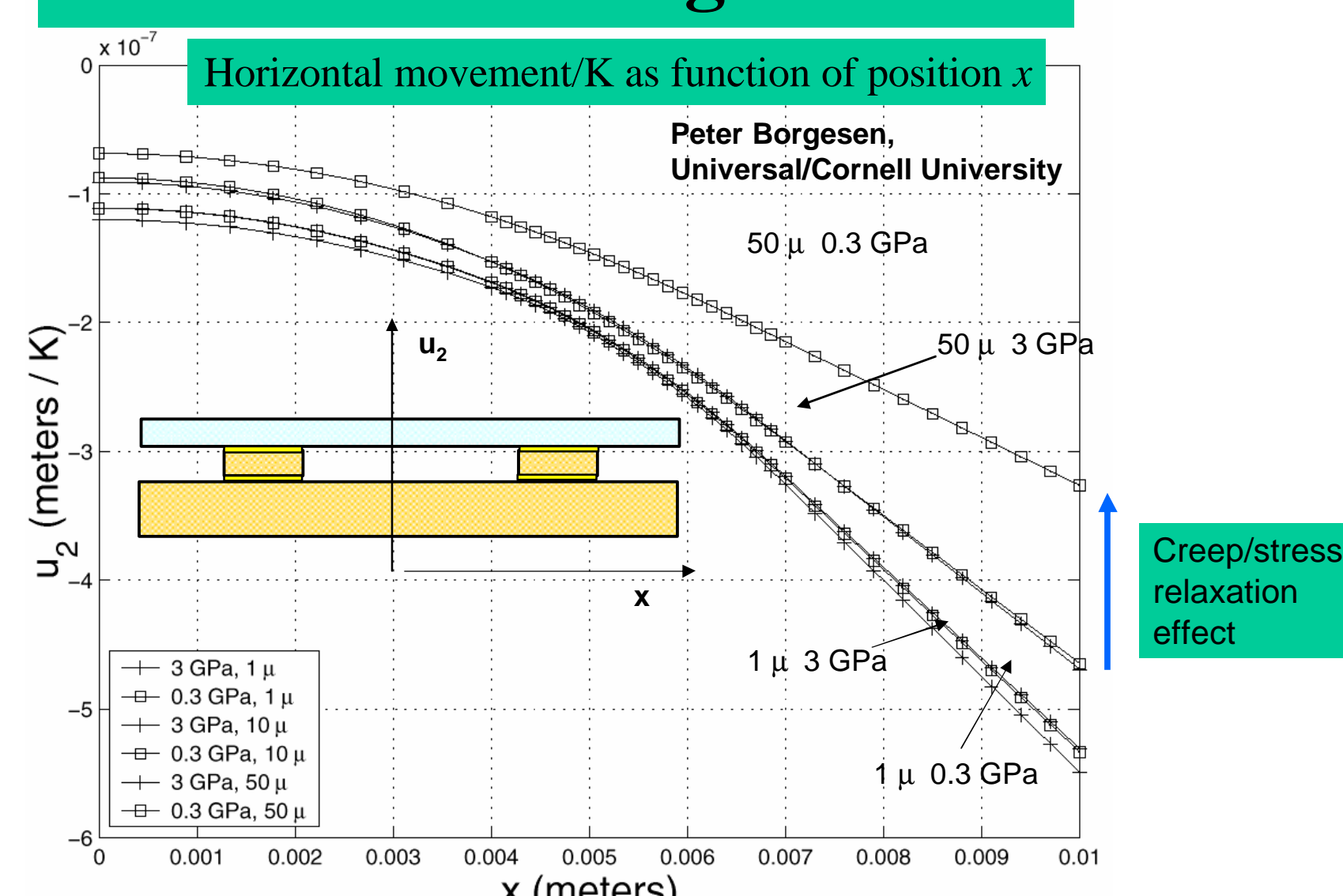

Future Work

Phase 2.0

- Members only
- Task assignment
- Type of study
 - displacement measurement *more expensive*
 - optical coupling measurement *cheaper but may be uncertain*
- Cost

The Center for Optical Technologies (LU/Penn State) has signed an agreement with the High Density Packaging Users Group to provide leadership for Phase 2.0!