

# Thermochemical Processing Effects at Multicomponent Glass Surfaces

Carlo G Pantano  
Department of Materials Science and Engineering  
Materials Research Institute  
The Pennsylvania State University

Acknowledgements: Bob Hengstebeck  
Justin Wood  
CQ Shen  
Elam Leed  
Rob Schaut  
Prof Karl Mueller  
NSF Center for Glass Research



IMI – NFG Winter School,  
January 2008, Kyoto, Japan

Materials Research Institute  
Center for Glass Surfaces, Interfaces and Coatings

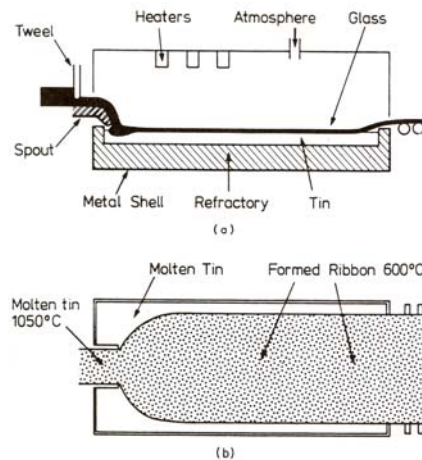

**Figure 20-14.** Float glass process. (a) Float bath. (b) Equilibrium mode of operation (After W. C. Hynd., in *Glass Science & Tech.*, vol. 2, Processing I (D. R. Uhlmann and N. J. Kreidle, eds.), Fig. 14. p. 86. Academic Press, New York, 1984).

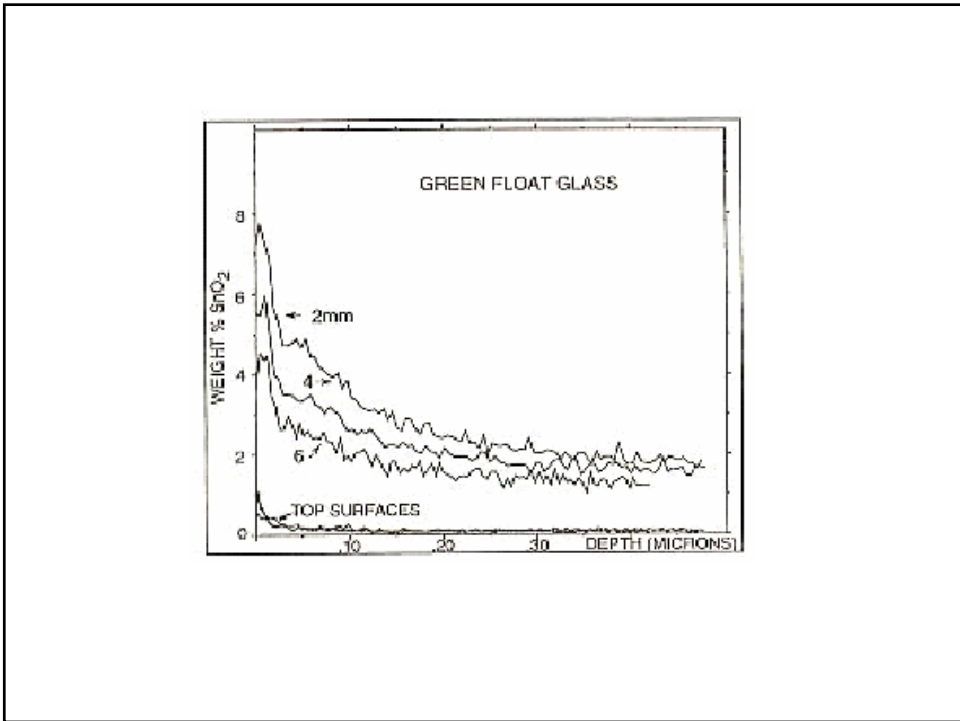
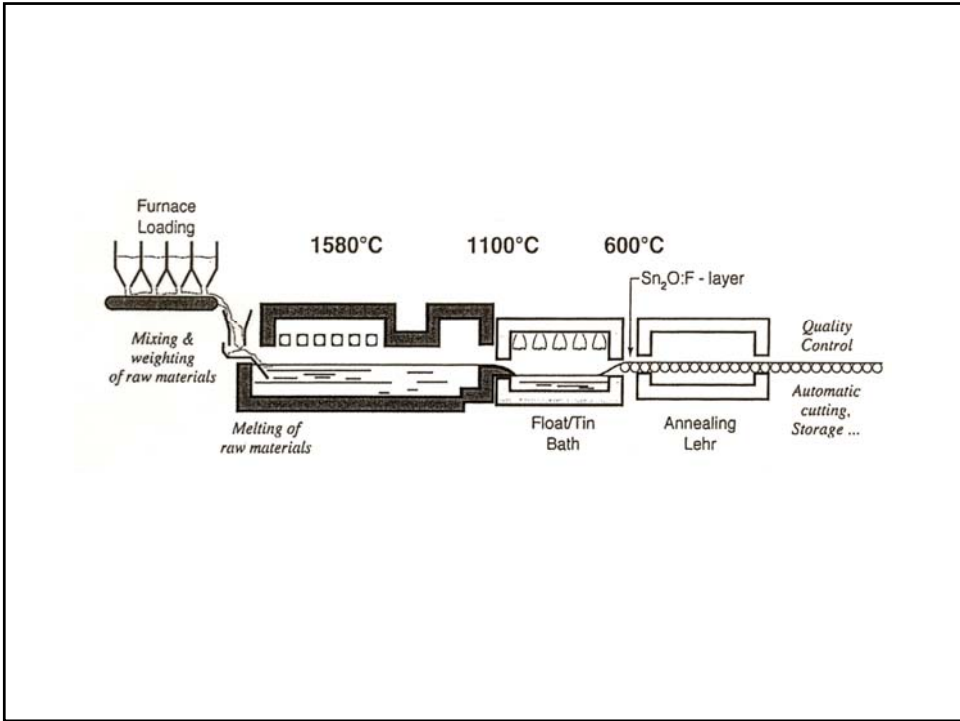

## How are flat, thin glass sheetss made?



Homogenous, conditioned glass flows over a weir, downward a blade, through a nozzle, or on a spinning drum to form a film which is continuously withdrawn

The thickness of the formed film is a function of ...

- the glass viscosity
- the surface tension
- the drawing speed and flow rate

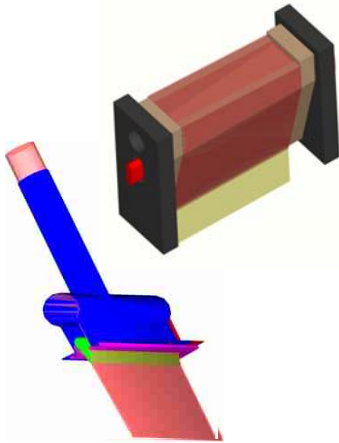

### Challenges:

- Surfaces in glass contact have to be precision-machined for ultra-thin glass
- Components have to keep alignment during heat-up and during operation
- Precise temperature control needed to avoid viscosity differences which lead to thickness variations, and potentially devitrification

### FUSION PROCESS FOR MICROSHEET GLASS FABRICATION

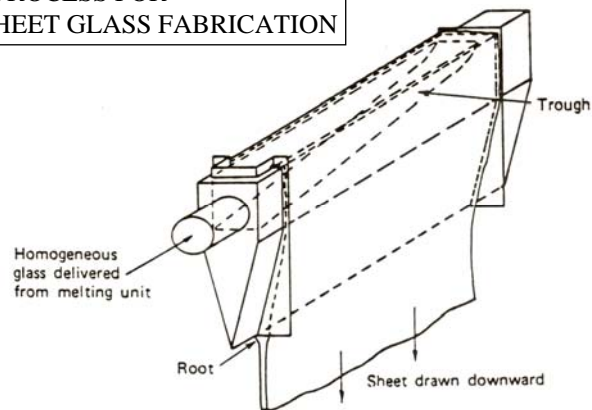

### Antimony Depth Distribution by Angle-Resolved XPS and FAB-Static SIMS

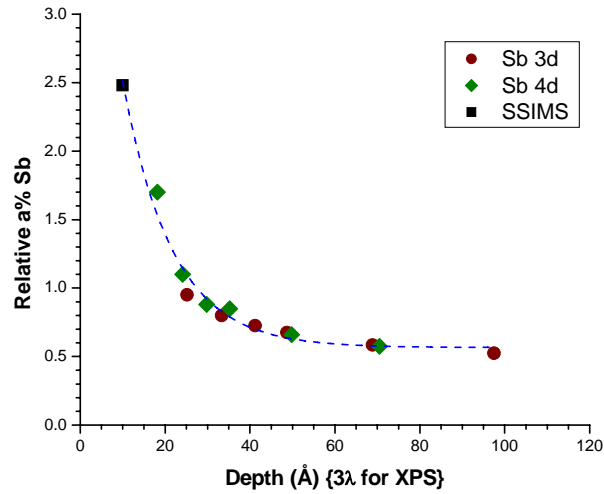

### Antimony Depth Distribution by Angle-Resolved XPS and FAB-Static SIMS

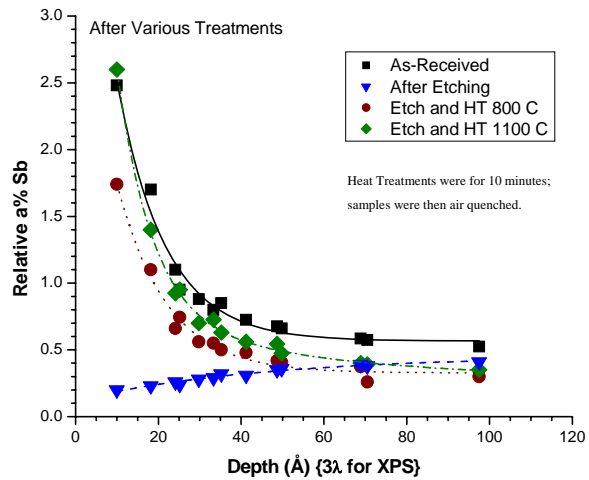

surface composition by FAB SIMS for commercial microsheet glass for FPD

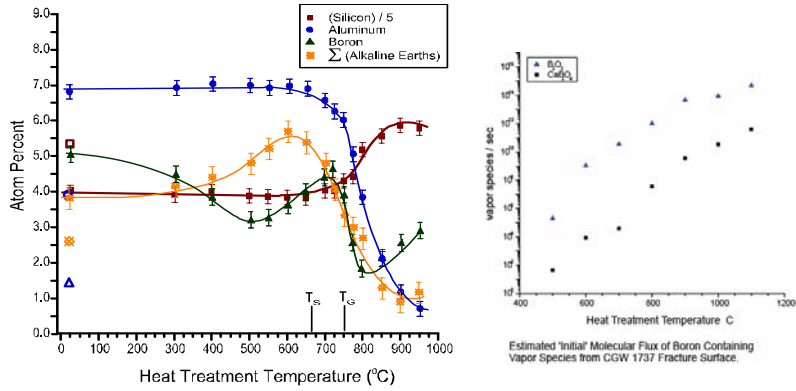

Isothermally 'Freezing In' the Surface Composition

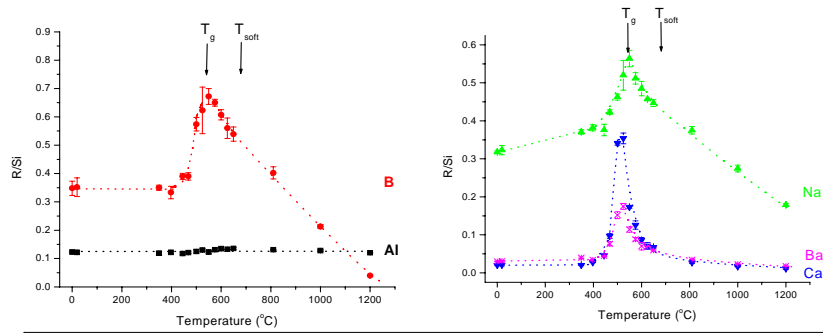

- after heat-treatment at T<sub>g</sub>, the surface is depleted in Si. The concentrations of B, Na, Ba and Ca increase significantly on the surface, especially Ca and Ba.
- At temperatures > 800 °C, the surface is depleted in B and Na.
- The Al/Si ratio does not change over the entire temperature range.

## Glass VII

**XPS Depth Profiling:**  
air-fracture surface of glass I,  
“equilibrated” at 525 °C.

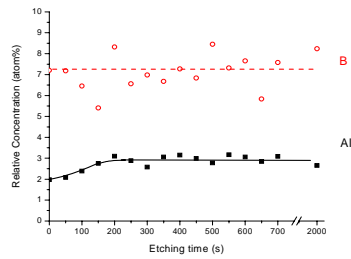

- Sputtering rate  $\sim 1 \text{ \AA/s}$ .
- The Si-depleted layer  $\sim 200 \text{ \AA}$  thick.

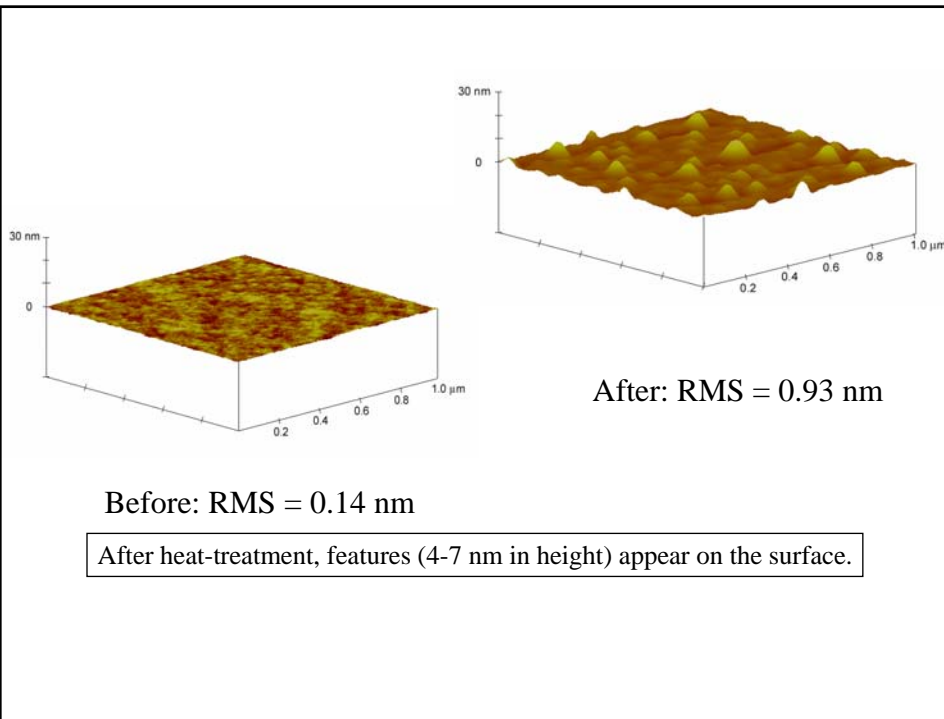
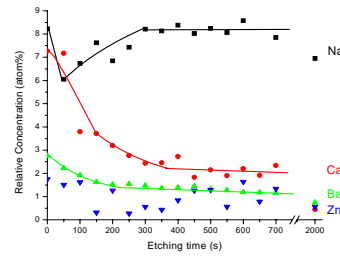
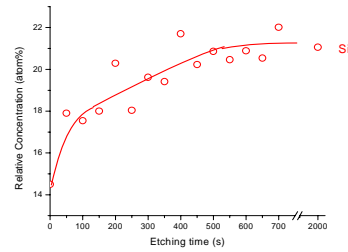

## Phenomenological Model for “Phase Segregation/Migration” to the Surface

■ Network modifier rich region
 ■ Network former rich region

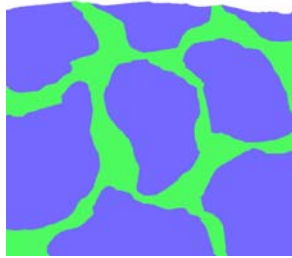

Before Heat-treatment

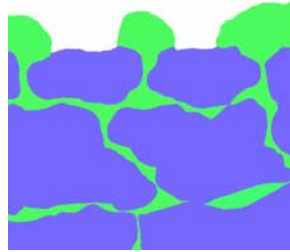

After Heat-treatment

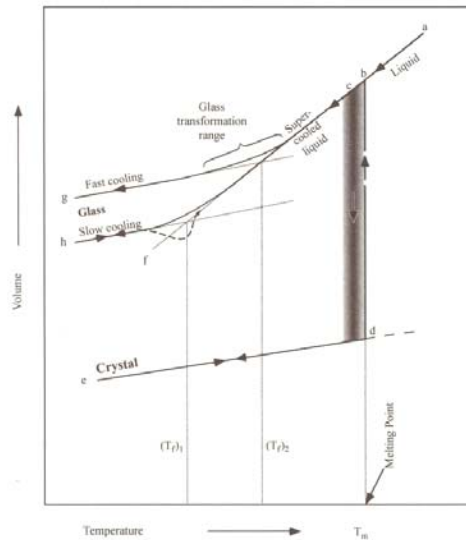
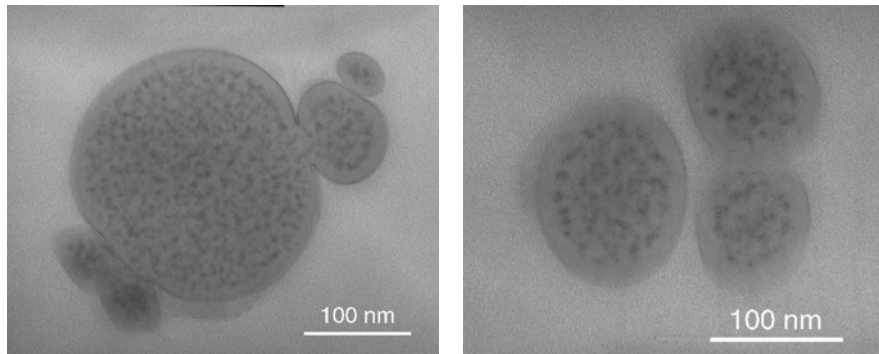
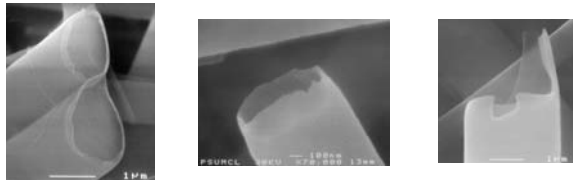

FIGURE 5.1 The volume-temperature diagram. (After A. K. Varshneya, *Fundamentals of Inorganic Glasses*, Fig. 2-1, p. 15, Academic Press, 1994.)

## TEM of FA Fibers (Glass A)



after leaching →



## Issues and Opportunities at Glass Surfaces

- At high temperature, surface segregation, evaporation, redox, and other surface localized thermochemical phenomena can occur. Upon reaching the  $T_g$ , the modified surface composition is frozen in.
- The creation of glass surfaces at high temperature provides the opportunity to modify the surface of glass fibers or substrates independent of the bulk in some systems; ie, to decouple the bulk glass requirements (processability and optical properties) from the surface requirements (composition and chemical reactivity). **What do you think?**